

Océ 9300

User Manual





Océ-Technologies B.V.

This manual contains a description of the Océ 9300 system and a detailed explanation of the plot functions. The introduction (chapter 1), gives a general description of the working methods employed in using the copier and we recommend that you read at least this chapter.

Safety information

This manual contains the following safety information:

- Appendix C lists 'Instructions for safe use'. *We advise you to read this information before you start to actually use the copier.* Technical safety information such as safety data sheets can also be found in appendix C.
- Where applicable, cautions and warnings are used throughout this manual to draw your attention to the safety precautions which you should follow.

Trademarks

PostScript is a trademark of Adobe Systems Inc.

HP-GL, HP-GL/2, HP-RTL are trademarks of Hewlett Packard Company. Microsoft, MS, and MS-DOS are registered trademarks of Microsoft Corporation.

MS-Windows is a trademark of Microsoft Corporation.

CalComp is a trademark of California Computer Products Inc.

TIFF is a trademark of Aldus Corporation.

CALS is a military standard.

Copyright

Océ-Technologies B.V. Venlo, The Netherlands © 2000

All rights reserved. No part of this work may be reproduced, copied, adapted, or transmitted in any form or by any means without written permission from Océ.

Océ-Technologies B.V. makes no representation or warranties with respect to the contents hereof and specifically disclaims any implied warranties of merchantability or fitness for any particular purpose.

Further, Océ-Technologies B.V. reserves the right to revise this publication and to make changes from time to time in the content hereof without obligation to notify any person of such revision or changes.

Table of Contents

Chapter 1

Getting started

- The Océ 9300 printer 8
- The printer operating panel 9
 - Buttons 10
 - Display 11
- Turning the printer on or off 12

Chapter 2

Installing the printer

- Connect the printer to your host environment 14
- Centronics 15
- Serial 16
 - Handshake protocol 16
 - Baud rates 17
 - Bits combination 18
 - Serial parity and stop bits 18
 - Port type 19
 - Turnaround delay 20
 - Inter-character delay 21
- Configuring the printer's memory 22
 - Input buffer 22
 - Bitmap buffer 23

Chapter 3

(Re)load media and toner

- Inserting a new print media roll 26
 - Automatic roll switching 26
 - Reloading rolls 27
 - Cutting print media to attain a straight leading edge 30
- Printing using the manual feed 33
- Programming media settings 34
- Refilling toner 37

Chapter 4

Printing files

- Printing files 40
 - Océ application 41
 - Océ drivers 41
 - Cut method 42
 - Plot Center 42
 - Leading/trailing edge 43
 - Demo plot 44
 - Cancel plot 44

Chapter 5

Customizing defaults

- Defining pen settings 46
- Defining language settings 48
 - Automatic language sensing 48
 - Data format recognition 49
 - Manual data format selection 50
- Océ languages (VDF/BGL) 51
 - Océ print origin 51
 - Océ step size 52
 - Océ pen priority 53
- HP-GL 54
 - HP-GL print origin 54
 - HP-GL page advance 54
 - Merge mode 55
- HP-GL/2 56
 - HP-GL/2 print origin 56
 - HP-GL/2 page advance 56
 - HP-GL/2 pen priority 57
 - Designjet compatibility 58
 - Merge mode 58
 - Line Attribute 59
- HP-RTL 60
- CalComp 61
 - CalComp print origin 61
 - Checksum parameter 62
 - CalComp pen priority 62
 - Merge mode 63
 - End of Message parameter 63
 - Synchronization code parameter 64
 - Double synchronization code parameter 65
 - CalComp step size 66

Raster formats	67
CALS	67
NIRS	67
TIFF	67
C4 (EDMICS)	67
PostScript level 2	68
PostScript data format selection	68
Manual data format selection	68
PostScript page layout	69
Default PostScript page size	69

Chapter 6

Advanced menu functions

Introduction	72
End of plot time out	73
Selecting the media saver	74
Nesting	74
Autoposition	76
Media saver time-out	77
Flush media saver	77
Media saver plot size	78
Replot	79
Setting the number of copies	79
Quality setup	80
Poster mode	80
Rendering	81
Image type	82
Transformation	83
Print rotation	83
Print scaling	83
Autoscaling	84
Password	87
Dump configuration	88
Service	89

Chapter 7

Solving problems

Solving problems	92
Printer warnings	92
Operator recoverable errors	93
Clearing paper jams	94
Machine-recoverable errors	96

Appendix A

Overview and tables

- Product specifications 98
- Interfaces 99
 - Centronics protocol 99
 - Serial protocols 99
 - Ethernet protocol 100
- Centronics port configuration 101
- Serial port configuration 102
- Print media that can be used 103

Appendix B

Hardware components and operating panel

- Océ 9300 106
- Operating panel 107

Appendix C

Safety information

- Instructions for safe use 110
- Safety data sheets 111
 - Safety data sheet Océ 9300 printer 112

Appendix D

Miscellaneous

- How to read this manual 114
- User survey 115
- Addresses of local Océ organizations 117
- Index 119

Chapter 1

Getting started

This chapter contains a general description Océ 9300 of how to install and set up the printer to be ready for use.



The Océ 9300 printer

The Océ 9300 is a wide-format printing system. The machine is equipped with an automatic 1- or 2-roll dispenser. The Océ 9300 prints on paper, transparencies, vellum, and polyester film. Its powerful digital technology offers users optimal ease of use and the reliability that you have come to expect of Océ.

The following are some of the features included in this machine:

- automatic language sensing and remote control
- multiple interfaces
- fast, high quality printing
- autoscaling of vector data
- media saver

Optional features:

- automatic 2-roll unit
- memory extension modules
- PostScript level 2
- Ethernet interface
- high-capacity delivery tray

Note: *The optional features can vary from one country to another.*

The printer operating panel

The operating panel located on the right-hand side of the printer console is easy to use (see figure 1). The panel consists of buttons and a display.

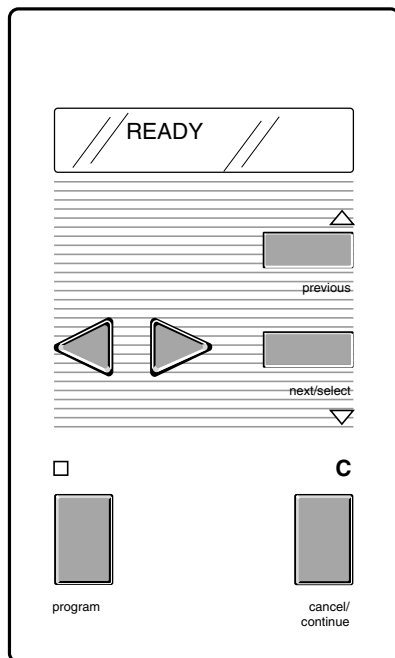

[1] Printer operating panel

During normal operation, the printer can process print jobs and provide a 2-line display of the current printer status (e.g. 'READY' or 'RASTERIZING').

The buttons on the operating panel allow you to enter the Program mode and easily set up the printer according to your requirements.

Buttons

'Program' To activate the program mode and to enter the top level menu. In this mode, the user can use 'next/select' the 'previous' and ◀ or ▶ buttons to step through the menu.

Press 'Program' again. If no action takes place for 1 minute in Program mode, the machine will return to the status mode.

Note: *If you press the Program button while the printer is printing, the LED above the program button flashes. As soon as the printing process is ready, you will automatically enter the program mode. Keep in mind that the printer will not print in Program mode.*

'Next/select' To select an option or a setting in the menu. Or, if a submenu is present, enter a lower-level menu.

'Previous' Pressing this button takes you one level higher in the menu structure.

Browse buttons ◀ or ▶ These two buttons are used to select another mode at the same menu level, or to display the next or previous option from the option list.

'Cancel/continue' This button is used to cancel the current print job or to continue after an operator-recoverable error.

Display

The two-line LCD display provides status information on print jobs in normal mode, and displays menu items in Program mode.

The following messages may appear during normal operation:

Status messages indicates the actual status of the printer, e.g. 'READY', 'PROCESSING' etc.

Warning messages the printer will continue to operate during a warning message; however, it is likely that the print quality will not be optimal, e.g. 'REFILL TONER'.

Error messages The printer stops and the user must take action, e.g. 'PAPER JAM'.

Action messages An action message prompts the user to perform an action before the print job resumes. For example: 'FEED SHEET' in the case of manual feed.

Turning the printer on or off

Once the printer has been turned on, it is ready for operation.

▼ Turning the printer on

- 1 Set the on/off switch, located at the back of the printer, to position '1' (see figure 2). If the electrical supply is correctly connected, the green switch will light up.

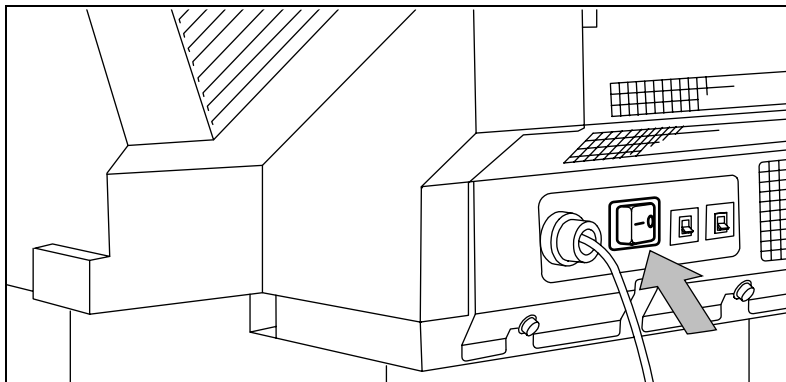

[2] Printer on/off switch

Note: When 'Ready' appears on the operating panel, the printer is ready for use.

▼ Turning the printer off

- 2 Set the on/off switch, located at the back of the printer, to position '0' (see figure 2).

Attention: Turning the printer off during a print job may cause a loss of information or a paper jam.

Chapter 2

Installing the printer

This chapter describes how to connect your printer to your host environment and how to configure the printer to meet your specific needs.



Connect the printer to your host environment

The Océ 9300 supports several types of interfaces (Serial, Centronics, TCP/IP, Novell Netware, NETBIOS, Ethertalk).

To ensure proper operation, please follow the steps below when connecting your host to the Océ 9300.

- 1** Make sure that both the host and the Océ 9300 are turned OFF (see 'Centronics' on page 15).
- 2** Connect the appropriate interface cable to your local host and the corresponding interface connector to the Océ 9300 (see 'Centronics' on page 15) or (see 'Configuring the printer's memory' on page 22).
- 3** Turn on the Océ 9300 (see 'Centronics' on page 15).
- 4** Enter the Program mode in order to configure the connection parameters (see 'Centronics' on page 15) or (see 'Configuring the printer's memory' on page 22).
- 5** Enter the Program mode to in order to configure the Océ 9300 to your requirements (see 'Printing files' on page 40) or (see 'Customizing defaults' on page 45).
- 6** Leave Program mode, the printer is ready for use. If applicable, install and configure the appropriate host software on your local host environment.

Centronics

Connection through the Centronics interface is direct and data transfer is fast. You must set two parameters: the transmission type and the plot time-out.

▼ **Connecting Centronics**

- 1 Turn off the printer and host.
- 2 Connect one end of the Centronics cable to the computer's Centronics parallel port.
- 3 Connect the other end to the printer's Centronics parallel port (see figure 3).

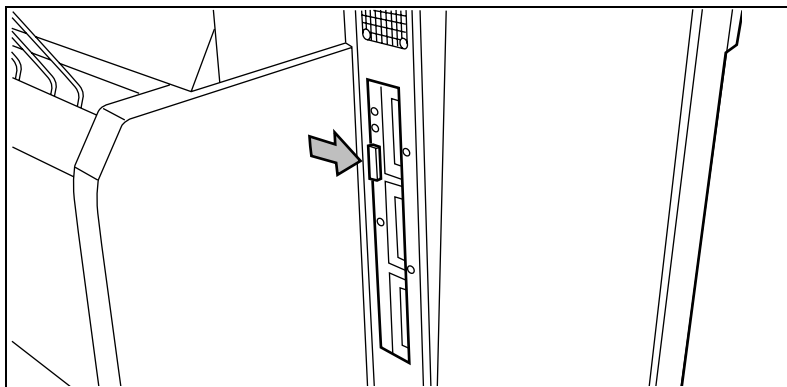

[3] Centronics port

- 4 Turn the printer on.

▼ **Defining transmission speed**

- 1 Press 'Program' to enter the main menu.
- 2 Select the 'CONFIGURATION' menu using the ◀ or ▶ button.
- 3 Press 'next/select' to enter the 'CONFIGURATION' menu.
- 4 Select the 'CONNECTIONS' menu using the ◀ or ▶ button.
- 5 Press 'next/select' to enter the 'CONNECTION' menu.
- 6 Select the 'CENTRONICS' item using the ◀ or ▶ button.
- 7 Press 'next/select' to enter the 'CENTRONICS' menu.
- 8 Select the required speed using the ◀ or ▶ button.
- 9 Press 'next/select' to confirm the selected speed.
- 10 Press 'Program' to exit the main menu.

Serial

If you are using the serial port, you will need to configure a list of parameters. All required parameters are described in the following procedures.

▼ Connecting serial

- 1 Turn off the printer and host
- 2 Connect one end of the serial cable to the computer's serial port.
- 3 Connect the other end to the printer's Serial port (see figure 4).

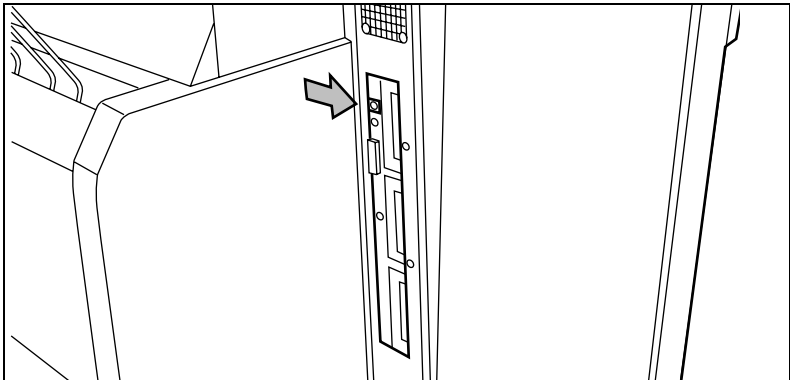

[4] Serial port

- 4 Turn the printer on.

Handshake protocol

You can select CTS2 or XON4 or BOTH. The default setting is *BOTH*. This means that the printer will automatically respond to either XON/XOFF (software protocol) or CTS (hardware protocol).

▼ Defining handshake protocol

- 1 Press 'Program' to enter the main menu.
- 2 Select the 'CONFIGURATION' item using the ◀ or ▶ button.
- 3 Press 'next/select' to enter the 'CONFIGURATION' menu.
- 4 Select the 'CONNECTIONS' item using the ◀ or ▶ button.
- 5 Press 'next/select' to enter the 'CONNECTIONS' menu.
- 6 Select the 'SERIAL' item using the ◀ or ▶ button.
- 7 Press 'next/select' to enter the 'SERIAL' menu.

- 8 Select the 'PROTOCOL' item using the ◀ or ▶ button.
- 9 Press 'next/select' to enter the 'PROTOCOL' menu.
- 10 Select the 'XON_XOFF' item using the ◀ or ▶ button.
- 11 Press 'next/select' to enter the 'XON_XOFF' menu.
- 12 Select the appropriate setup using the ◀ or ▶ button.
- 13 Press 'next/select' to confirm the selected setup.
- 14 Press 'Program' to leave the main menu.

Baud rates

The printer supports the following baud rates: 300, 600, 1200, 2400, 4800, 9600, 19200 and 38400. Default is 9600.

▼ Defining the baud rate

- 1 Press 'Program' to enter the main menu.
- 2 Select the 'CONFIGURATION' item using the ◀ or ▶ button.
- 3 Press 'next/select' to enter the 'CONFIGURATION' menu.
- 4 Select the 'CONNECTIONS' item using the ◀ or ▶ button.
- 5 Press 'next/select' to enter the 'CONNECTIONS' menu.
- 6 Select the 'SERIAL' item using the ◀ or ▶ button.
- 7 Press 'next/select' to enter the 'SERIAL' menu.
- 8 Select the 'TRANSMISSION' item using the ◀ or ▶ button.
- 9 Press 'next/select' to enter the 'TRANSMISSION' menu.
- 10 Select the 'BAUD RATE' item using the ◀ or ▶ button.
- 11 Press 'next/select' to enter the 'BAUD RATE' menu.
- 12 Setup the required baud rate using the ◀ or ▶ button.
- 13 Press 'next/select' to confirm the selected baud rate.
Note: *Choose the fastest baud rate compatible with your system.*
- 14 Press 'Program' to leave the main menu.

Bits combination

When transmitting data via the serial interface, 8 or 7 bits per byte are used.
The default is 8.

▼ Defining the bits combination

- 1 Press 'Program' to enter the main menu.
- 2 Select the 'CONFIGURATION' item using the ◀ or ▶ button.
- 3 Press 'next/select' to enter the 'CONFIGURATION' menu.
- 4 Select the 'CONNECTIONS' item using the ◀ or ▶ button.
- 5 Press 'next/select' to enter the 'CONNECTIONS' menu.
- 6 Select the 'SERIAL' item using the ◀ or ▶ button.
- 7 Press 'next/select' to enter the 'SERIAL' menu.
- 8 Select the 'TRANSMISSION' item using the ◀ or ▶ button.
- 9 Press 'next/select' to enter the 'TRANSMISSION' menu.
- 10 Select the 'BAUD RATE' item using the ◀ or ▶ button.
- 11 Press 'next/select' to enter the 'BAUD RATE' menu.
- 12 Select the number of bits per byte using the ◀ or ▶ button.
- 13 Press 'next/select' to confirm the selected number of bits.
- 14 Press 'Program' to leave the main menu.

Serial parity and stop bits

For correct data transfer, the parity and stop bits (framing) are required. You can select the following combinations:

- None, 1 stop No parity, 1 stop bit
- None, 2 stop No parity, 2 stop bits
- Even, 1 stop Even parity, 1 stop bit
- Even, 2 stop Even parity, 2 stop bits
- Odd, 1 stop Odd parity, 1 stop bit
- Odd, 2 stop Odd parity, 2 stop bits

Default is NONE, 1 STOP

▼ Setting the parity and stop bits

- 1 Press 'Program' to enter the main menu.
- 2 Select the 'CONFIGURATION' item using the ◀ or ▶ button.
- 3 Press 'next/select' to enter the 'CONFIGURATION' menu.
- 4 Select the 'CONNECTIONS' item using the ◀ or ▶ button.

- 5 Press 'next/select' to enter the 'CONNECTIONS' menu.
- 6 Select the 'SERIAL' item using the ◀ or ▶ button.
- 7 Press 'next/select' to enter the 'SERIAL' menu.
- 8 Select the 'TRANSMISSION' item using the ◀ or ▶ button.
- 9 Press 'next/select' to enter the 'TRANSMISSION' menu.
- 10 Select the 'FRAMING' item using the ◀ or ▶ button.
- 11 Press 'next/select' to enter the 'FRAMING' menu.
- 12 Select the appropriate parity and number of stop bits using the ◀ or ▶ button.
- 13 Press 'next/select' to confirm the selected parity and number of stop bits.
- 14 Press 'Program' to leave the main menu.

Port type

In order to give the maximum connection flexibility, the printer's serial port can be set to either DTE (data terminal equipment) or DCE (data communications equipment). The default is DTE.

▼ Selecting the port type

- 1 Press 'Program' to enter the main menu.
- 2 Select the 'CONFIGURATION' item using the ◀ or ▶ button.
- 3 Press 'next/select' to enter the 'CONFIGURATION' menu.
- 4 Select the 'CONNECTIONS' item using the ◀ or ▶ button.
- 5 Press 'next/select' to enter the 'CONNECTIONS' menu.
- 6 Select the 'SERIAL' item using the ◀ or ▶ button.
- 7 Press 'next/select' to enter the 'SERIAL' menu.
- 8 Select the 'PROTOCOL' item using the ◀ or ▶ button.
- 9 Press 'next/select' to enter the 'PROTOCOL' menu.
- 10 Select the 'PORT' item using the ◀ or ▶ button.
- 11 Press 'next/select' to enter the 'PORT' menu.
- 12 Select the appropriate port using the ◀ or ▶ button.
- 13 Press 'next/select' to confirm the selected port.
- 14 Press 'Program' to leave the main menu.

Note: *The printer's serial interface conforms to the RS-232-C and RS-423-C standards. If your computer uses the RS-423-C serial interface, the port type must be set to DTE.*

Turnaround delay

The printer offers possible delays from 0 to 10 seconds, with increments of 0.01 second. The default is 1.0.

▼ **Setting the turnaround delay**

- 1 Press 'Program' to enter the main menu.
- 2 Select the 'CONFIGURATION' item using the ◀ or ▶ button.
- 3 Press 'next/select' to enter the 'CONFIGURATION' menu.
- 4 Select the 'CONNECTIONS' item using the ◀ or ▶ button.
- 5 Press 'next/select' to enter the 'CONNECTIONS' menu.
- 6 Select the 'SERIAL' item using the ◀ or ▶ button.
- 7 Press 'next/select' to enter the 'SERIAL' menu.
- 8 Select the 'PROTOCOL' item using the ◀ or ▶ button.
- 9 Press 'next/select' to enter the 'PROTOCOL' menu.
- 10 Select the 'DELAY' item using the ◀ or ▶ button.
- 11 Press 'next/select' to enter the 'DELAY' menu.
- 12 Select the 'TURNAROUND' item using the ◀ or ▶ button.
- 13 Press 'next/select' to enter the 'TURNAROUND' menu.
- 14 Select the required delay using the ◀ or ▶ button.
- 15 Press 'next/select' to confirm the selected delay.
- 16 Press 'Program' to leave the main menu.

Inter-character delay

The printer offers possible delays from 0 to 10 seconds, with increments of 0.01 second. The default is 1.0.

▼ **Setting the inter-character delay**

- 1 Press 'Program' to enter the main menu.
- 2 Select the 'CONFIGURATION' item using the ◀ or ▶ button.
- 3 Press 'next/select' to enter the 'CONFIGURATION' menu.
- 4 Select the 'CONNECTIONS' item using the ◀ or ▶ button.
- 5 Press 'next/select' to enter the 'CONNECTIONS' menu.
- 6 Select the 'SERIAL' item using the ◀ or ▶ button.
- 7 Press 'next/select' to enter the 'SERIAL' menu.
- 8 Select the 'PROTOCOL' item using the ◀ or ▶ button.
- 9 Press 'next/select' to enter the 'PROTOCOL' menu.
- 10 Select the 'DELAY' item using the ◀ or ▶ button.
- 11 Press 'next/select' to enter the 'DELAY' menu.
- 12 Select the 'INTER CHAR' item using the ◀ or ▶ button.
- 13 Press 'next/select' to enter the 'INTER CHAR' menu.
- 14 Select the required delay using the ◀ or ▶ button.
- 15 Press 'next/select' to confirm the selected delay.
- 16 Press 'Program' to leave the main menu.

Configuring the printer's memory

The printer's memory partitions can be configured based on the anticipated complexity of print jobs.

Input buffer

This option enables you to set the print spool input buffer size. You can select a small or large buffer. A small buffer leaves more memory available for processing more complex files. A large buffer frees the host machine sooner. The default is 'large'.

Files in the input buffer will be processed and printed in the same order they arrive.

▼ **Setting the input buffer size**

- 1 Press 'Program' to enter the main menu.
- 2 Select the 'CONFIGURATION' item using the ◀ or ▶ button.
- 3 Press 'next/select' to enter the 'CONFIGURATION' menu.
- 4 Select the 'BUFFERS' item using the ◀ or ▶ button.
- 5 Press 'next/select' to enter the 'BUFFERS' menu.
- 6 Select the 'INPUT BUFFER' item using the ◀ or ▶ button.
- 7 Press 'next/select' to enter the 'INPUT BUFFER' menu
- 8 Select the required input buffer size using the ◀ or ▶ button.
- 9 Press 'next/select' to confirm the selected size.
- 10 Press 'Program' to leave the main menu.

▼ **Activating the new input buffer size**

- 1 Turn the printer off and then on again.

Note: *If you do not restart the printer, the new memory allocation is not activated. Any print data in the printer's memory (files in the queue) will be lost when you turn off the printer.*

Bitmap buffer

This buffer defines a percentage of the total RAM memory that can be used as the bitmap partition. This value will be set between two values, depending on the RAM configuration.

The installed RAM can be divided into the following sections:

- Bitmap partition
- Processing area for files

The size of the bitmap partition determines the max. dimensions of the image to be printed (e.g. 18 Mb = A0).

The size of the vector processing area determines the ability of the printer to process complex files (e.g. larger number of vectors).

A high-percentage allocation to the bitmap partition allows printing of long plots without windowing.

A low-percentage allocation to the bitmap partition enhances your ability to process very complex files (vector and raster).



Setting the bitmap buffer

- 1 Press 'Program' to enter the main menu.
- 2 Select the 'CONFIGURATION' item using the ◀ or ▶ button.
- 3 Press 'next/select' to enter the 'CONFIGURATION' menu.
- 4 Select the 'BUFFERS' item using the ◀ or ▶ button.
- 5 Press 'next/select' to enter the 'BUFFER' menu.
- 6 Select the 'BITMAP BUFFER' item using the ◀ or ▶ button.
- 7 Press 'next/select' to enter the 'BITMAP BUFFER' menu
- 8 Select the required bitmap partition using the ◀ or ▶ button
- 9 Press 'next/select' to confirm the required partition.
- 10 Press 'Program' to leave the main menu.

▼ **Activating the new bitmap buffer size**

- 1 Turn the printer off and then on again.

Note: *If you do not restart the printer, the new memory allocation is not activated. Any print data in the printer's memory will be lost when you turn off the printer.*

RAM	Min	Max
32	58 %	82 %
48	39 %	88 %
64	29 %	90 %

Note: *The presented memory percentages are only an indication and may vary slightly from one firmware release to another.*

Chapter 3

(Re)load media and toner

This chapter describes how to insert new media, how to add toner and how to program the media settings.



Inserting a new print media roll

Before using the copier for the first time, you must specify the order in which the paper formats appear on the scanner operating panel. You can do this by choosing between ISO, ANSI or ARCHITECT paper format on the printer operating panel.

▼ Setting the media format

- 1 Press 'Program' to enter the main menu.
- 2 Select the 'CONFIGURATION' item using the ◀ or ▶ button.
- 3 Press 'next/select' to enter the 'CONFIGURATION' menu.
- 4 Select 'PLOT MANAGER' using the ◀ or ▶ button.
- 5 Press 'next/select' to enter the 'PLOT MANAGER' menu.
- 6 Select 'MEDIA FORMAT' using the ◀ or ▶ button.
- 7 Press 'next/select' to enter the 'MEDIA FORMAT' menu.
- 8 Select the required format using the ◀ or ▶ button.
- 9 Press 'next/select' to confirm the selected format.
- 10 Press 'Program' to exit the main menu.

If the message 'ROLL EMPTY' appears in the display, you must load a new roll of print media. Depending on your configuration, you can reload roll 1 and/or roll 2.

Note: *After reloading, the plot is reprinted automatically.*

Automatic roll switching

If a roll becomes empty, the printer reports a roll empty error. When this happens, printing also stops. The printer clears the paper path and generates a message to indicate that the printer is ready to accept a new print command. If the correct material type and format is on the other roll, the printer will use that roll and will resume printing automatically.

If there is no match of material type and format, you must refill the empty roll.

▼ **Defining automatic roll switching**

- 1 Press 'Program' to enter the main menu.
- 1 Select the 'MEDIA SETTINGS' item using the ◀ or ▶ button.
- 2 Press 'next/select' to enter the 'MEDIA SETTINGS' menu.
- 3 Select 'MEDIA MODE' using the ◀ or ▶ button.
- 4 Press 'next/select' to enter the 'MEDIA MODE' menu.
- 5 Select 'AUTO SWITCH' using the ◀ or ▶ button.
- 6 Press 'next/select' to enter the 'AUTO SWITCH' menu.
- 7 Select the required setting 'On' or 'OFF' using the ◀ or ▶ button.
- 8 Press 'next/select' to confirm the selected setting.
- 9 Press 'Program' to exit the main menu

Reloading rolls

▼ **Reloading roll 1**

- 1 Open the drawer completely (see figure 5).

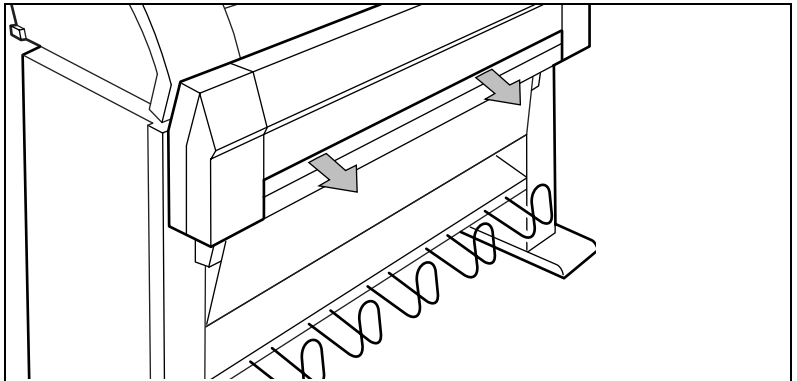

[5] Opening the drawer.

- 2 Remove the roll holder from the drawer (see figure 6 on page 28)

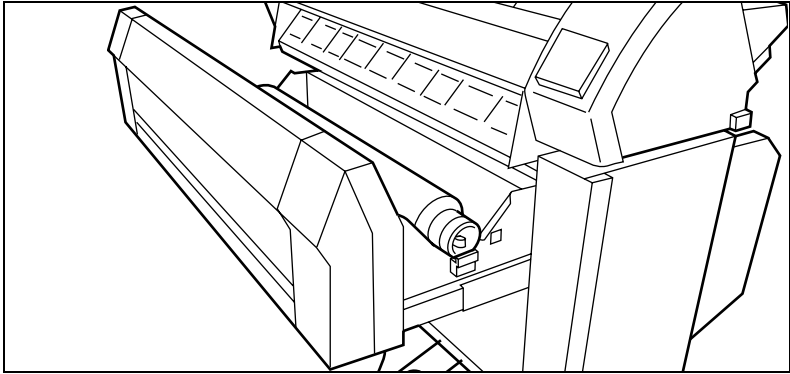

[6] Removing the roll holder from the drawer

- 3 While pressing the knob, remove the empty core from the roll holder (see figure 7).
- 4 Slide the roll holder into the new roll of material while pressing the knob (see figure 7).
Make sure that the knob is to the right, and that paper appears as shown in figure 7.

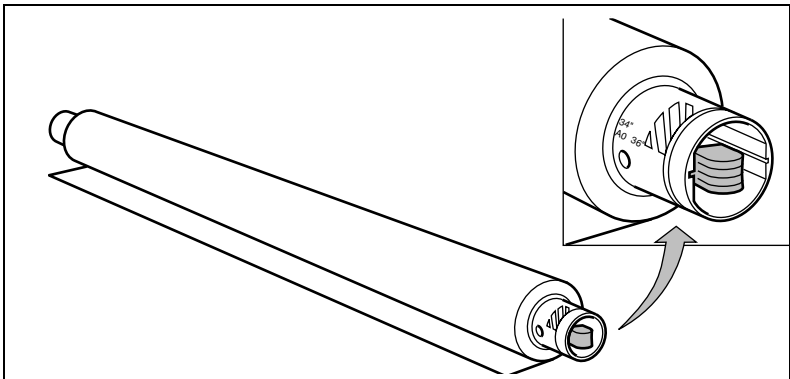

[7] Pressing the knob

- 5 While pressing the knob, align the roll with the appropriate lines on the roll holder. This line must be completely visible.

- 6** Place the roll holder with the material in the drawer (see figure 8).

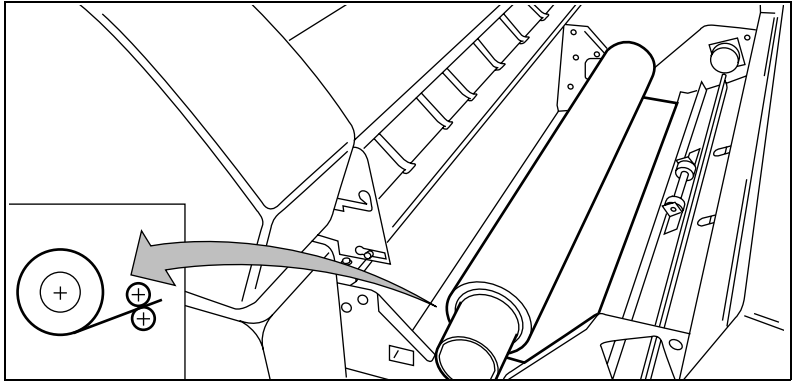

[8] Repositioning the roll

- 7** Feed the material between the input guide plates against the rollers.
- 8** Turn the rollers until the material is visible (see figure 9). You can also refer to the sticker inside the drawer.

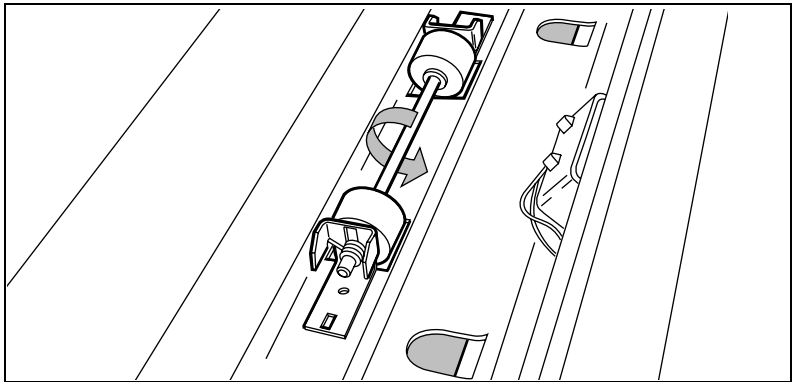

[9] Feeding print media

- 9** If you have inserted a roll with another material or with a different width, you have to program the correct width and material type (refer to 'Programming media settings' on page 34).
If you want to cut the paper to get a straight leading edge, see 'Cutting print media to attain a straight leading edge' on page 30.
Otherwise continue with the next step.
- 10** Close the drawer.
- 11** Press the 'Cancel/Continue' button.

Cutting print media to attain a straight leading edge

If the paper does not have a straight leading edge, you can cut it off at right angles from the roll.

▼ **Cutting the paper from roll 1 or roll 2**

- 1 Open the drawer.
- 2 Feed the paper manually until it is approximately 5 cm above the top drawer.
- 3 Close the paper drawer.
- 4 Press 'Program' to enter the main menu.
- 5 Select the 'MEDIA SETTINGS' item using the ◀ or ▶ button.
- 6 Press 'next/select' to enter the 'MEDIA SETTINGS' menu.
- 7 Select 'CUT MEDIA' using the ◀ or ▶ button.
- 8 Press 'next/select' to cut the paper.
- 9 Open the paper drawer.
- 10 Remove the scrap of material.
- 11 Pull back the material until it is visible and positioned correctly (see figure 9 on page 29).
- 12 Close the drawer.
- 13 Press the button 'Cancel/Continue'.

▼ **Reloading roll 2**

- 1 Open the cover to get access to roll 2 (see figure 10).

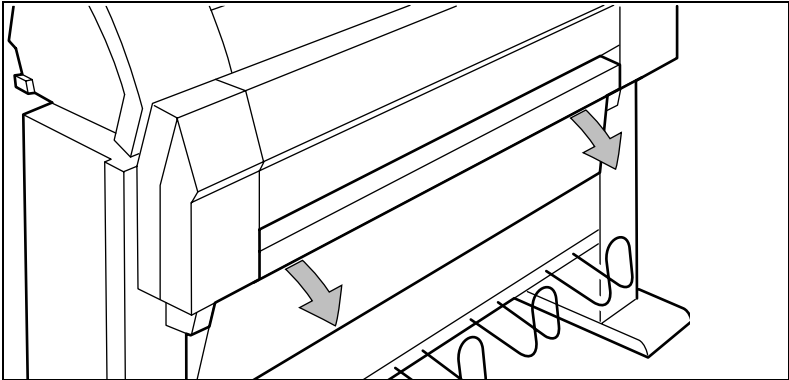

[10] Opening the lower compartment

- 2 Remove the roll holder (see figure 11).

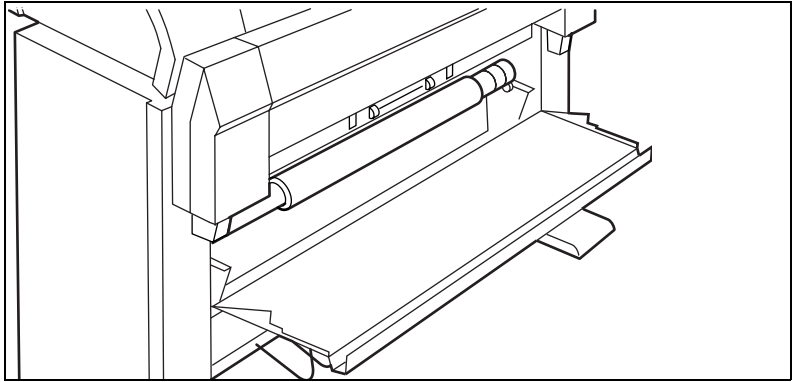

[11] Removing the roll holder from the lower compartment

- 3 While pressing the knob, remove the empty core from the roll holder (see figure 7 on page 28).
- 4 While pressing the knob, slide the roll holder into the roll of print material (see figure 7 on page 28).
Make sure that the knob is to the right, and that the paper appears as shown in figure 7.
- 5 While pressing the knob, align the roll with the appropriate lines on the roll holder.
- 6 Place the roll holder with the material in the lower paper compartment (see figure 12).

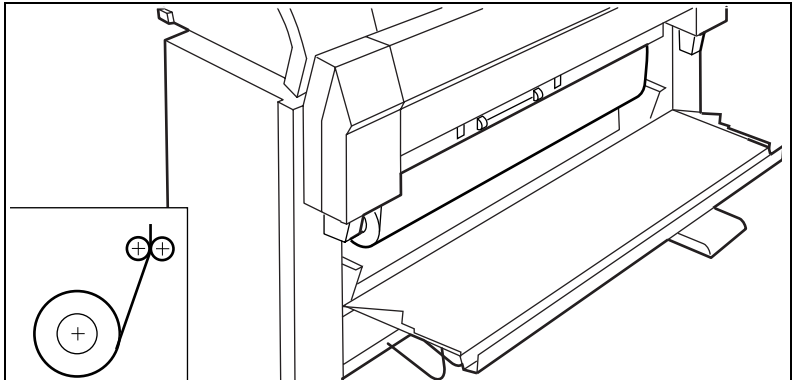

[12] Repositioning the roll

- 7 Feed the material between the input guide plates against the rollers. Turn the rollers until the material is visible (see figure 13). You can also refer to the sticker inside the drawer.

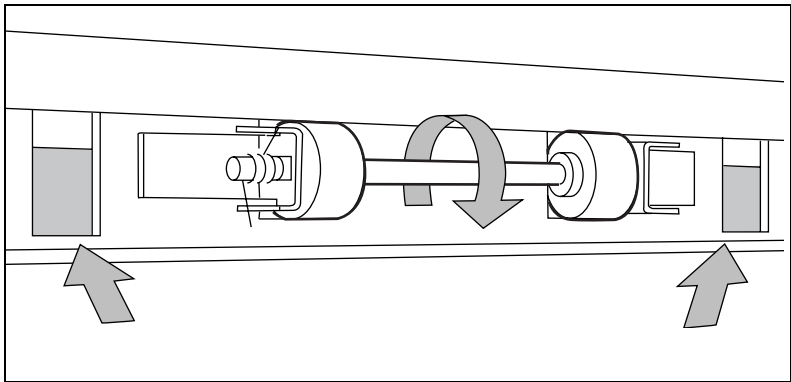

[13] Feeding print media

- 8 If you have inserted a roll with another media or with a different width, you have to program the correct width and media type (refer to 'Programming media settings' on page 34).
If you want to cut the paper to get a straight leading edge, see 'Cutting print media to attain a straight leading edge' on page 30.
Otherwise continue with the next step.
- 9 Close the lower paper compartment.
- 10 Press the 'Cancel/Continue' button.

Printing using the manual feed

Manual feed can be selected in two ways:

- Via remote control commands added to the print file (by means of Plot Director or drivers.)
- By changing the 'MEDIA MODE' in program mode.

If the user wants to use manual feed, he or she must:

- 1 Program the media settings on the printer; see 'Programming media settings' on page 34.
- 2 Send the file.
- 3 Wait until the message 'FEED SHEET' appears in the printer display.
- 4 Feed a sheet of paper into the printer in portrait orientation.
- 5 Hold the paper until the engine pulls in the first part of the sheet.

If the user has selected manual feed in a print file, the printer will ask the user, via the operating panel, to feed the sheet into the printer at the moment this job is processed. There will be a user-selectable time-out between 30 and 300 seconds for feeding the sheet. The default time-out is 60 seconds. See 'Setting the time-out for manual feed' on page 36. If the user does not feed the sheet within this time, the job is canceled and the next job is processed.



Inserting print material into the manual feed

- 1 Feed the print material centrally into the feed table in accordance with the guidelines (see figure 14).

Note: *The minimum length of the print material is 420 mm (16.5").*

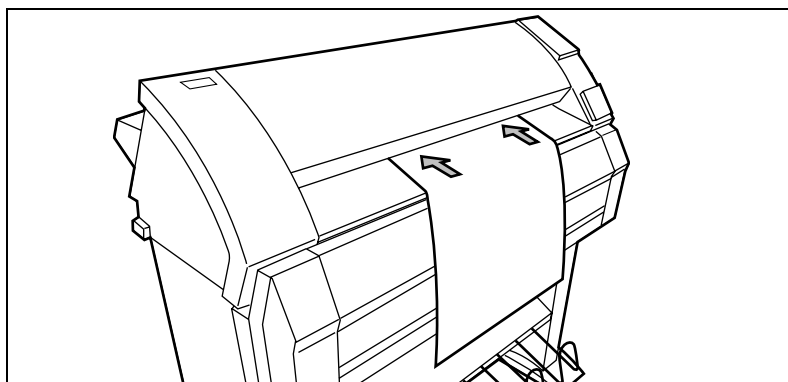

[14] Manual feed

Programming media settings

If you have inserted a new roll with a different media or of a different width, you must program the new roll specifications. These specifications are:

- width of the material.
You can select A0 (841 mm), A1 (594 mm), A2 (420 mm), A3 (297mm), E (34"), D (22"), C (17"), B (11"), E+ (36"), D+ (24"), C+ (18"), B+ (12"), 30", 500 mm, 700 mm and B1 (707 mm). The default is 36".
- Type of media
- Auto roll selection:
If you activate this function, the machine automatically selects the correct roll, depending on the size of the original.
- auto roll switch:
If you activate this function, the machine automatically switches to the other roll if the used one becomes empty. The switch only takes place if the media type and material width are the same for both rolls.

Materials	Weight	Media type setting
<i>Plain paper</i>	20 lb. bond	paper
<i>Plain paper</i>	27 lb. bond	paper
<i>ECO papers</i>	20 lb. bond	paper
<i>Translucent paper</i>	15 lb. bond	translucent
<i>Transparent paper</i>	21/22 lb.	transp <= 25 lb.
	24/25 lb.	transp <= 25 lb.
	27/28 lb.	transp 27 lb.
<i>Polyester film</i>	3.5 mil	film < =4 mil
<i>PPC film</i>	3.5 mil	film < =4 mil
<i>PPC Type C Polyester film</i>	3.5 mil	film < =4 mil
<i>Clear polyester film</i>	4 mil	film < =4 mil
<i>Contrast film</i>	3.5 mil	film < =4 mil
<i>Polyester film **</i>	4.5 mil	film 4.5 mil
<i>Vellum</i>	20 lb.	Vellum
<i>Vellum</i>	16 lb.	Vellum
<i>Contrast paper</i>	34 lb.	paper
<i>Fluor paper</i>	25 lb.	paper
<i>Pastel paper</i>	20 lb.	paper

** The sticker on this polyester roll indicates '4 mil', but the thickness is really 4.5 mil.

▼ **Programming media width settings**

- 1 Press 'Program' to enter the main menu.
- 2 Select the 'MEDIA SETTINGS' item using the ◀ or ▶ button.
- 3 Press 'next/select' to enter the 'MEDIA SETTINGS' menu.
- 4 Select 'ROLL 1', 'ROLL 2', 'MANUAL FEED' using the ◀ or ▶ button.
- 5 Press 'next/select' to enter the 'ROLL' or 'MANUAL FEED' menu.
- 6 Select the 'WIDTH' item using the ◀ or ▶ button.
- 7 Press 'next/select' to enter the 'WIDTH' menu.
- 8 Select the desired width using the ◀ or ▶ button.
- 9 Press 'next/select' to confirm the selected width.
- 10 Press 'Program' to exit the main menu.

▼ **Programming media type settings**

- 1 Press 'Program' to enter the main menu.
- 2 Select the 'MEDIA SETTINGS' item using the ◀ or ▶ button.
- 3 Press 'next/select' to enter the 'MEDIA SETTINGS' menu.
- 4 Select 'ROLL 1', 'ROLL 2', 'MANUAL FEED' using the ◀ or ▶ button.
- 5 Press 'next/select' to enter the 'ROLL' or 'MANUAL FEED' menu.
- 6 Select the 'TYPE' item using the ◀ or ▶ button.
- 7 Press 'next/select' to enter the 'TYPE' menu.
- 8 Select the desired media type using the ◀ or ▶ button.
- 9 Press 'next/select' to confirm the selected media type.
- 10 Press 'Program' to exit the main menu.

▼ **Programming default paper feed**

The default is roll 1.

- 1 Press 'Program' to enter the main menu.
- 2 Select the 'MEDIA SETTINGS' item using the ◀ or ▶ button.
- 3 Press 'next/select' to enter the 'MEDIA SETTINGS' menu.
- 4 Select 'MEDIA MODE' using the ◀ or ▶ button.
- 5 Press 'next/select' to enter the 'MEDIA MODE' menu.
- 6 Select the 'DEF. PAPER FEED' using the ◀ or ▶ button.
- 7 Press 'next/select' to enter the 'DEF. PAPER FEED' menu.
- 8 Select the default roll using the ◀ or ▶ button.
- 9 Press 'next/select' to confirm the selected mode.
- 10 Press 'Program' to exit the main menu.

▼ **Programming automatic roll selection**

- 1 Press 'Program' to enter the main menu.
- 2 Select the 'MEDIA SETTINGS' item using the ◀ or ▶ button.
- 3 Press 'next/select' to enter the 'MEDIA SETTINGS' menu.
- 4 Select 'MEDIA MODE' using the ◀ or ▶ button.
- 5 Press 'next/select' to enter the 'MEDIA MODE' menu.
- 6 Select 'AUTO ROLL' using the ◀ or ▶ button.
- 7 Press 'next/select' to enter the 'AUTO ROLL' menu.
- 8 Select on or off using the ◀ or ▶ button.
- 9 Press 'next/select' to confirm the selected mode.
- 10 Press 'Program' to exit the main menu.

▼ **Programming automatic switching**

- 1 Press 'Program' to enter the main menu.
- 2 Select the 'MEDIA SETTINGS' item using the ◀ or ▶ button.
- 3 Press 'next/select' to enter the 'MEDIA SETTINGS' menu.
- 4 Select 'MEDIA MODE' using the ◀ or ▶ button.
- 5 Press 'next/select' to enter the 'MEDIA MODE' menu.
- 6 Select 'AUTO SWITCH' using the ◀ or ▶ button
- 7 Press 'next/select' to enter the 'AUTO SWITCH' menu.
- 8 Select on or off using the ◀ or ▶ button.
- 9 Press 'next/select' to confirm the selected mode.
- 10 Press 'Program' to exit the main menu.

▼ **Setting the time-out for manual feed**

The default is 60 seconds.

- 1 Press 'Program' to enter the main menu.
- 2 Select the 'MEDIA SETTINGS' item using the ◀ or ▶ button.
- 3 Press 'next/select' to enter the 'MEDIA SETTINGS' menu.
- 4 Select 'MANUAL FEED' using the ◀ or ▶ button.
- 5 Press 'next/select' to enter the 'MANUAL FEED' menu.
- 6 Select the 'TIMEOUT' using the ◀ or ▶ button.
- 7 Press 'next/select' to enter the 'TIMEOUT' menu.
- 8 Select the desired time-out using the ◀ or ▶ button.
- 9 Press 'next/select' to confirm the selected time-out.
- 10 Press 'Program' to exit the main menu.

Refilling toner

If the message ‘REFILL TONER’ ---> Press Continue appears in the display, you must refill the toner immediately.

▼ Refilling toner

Attention: Use only Océ B4 toner.

- 1 Unscrew the access nut on the left side of the printer and open the left cover (see figure 15).

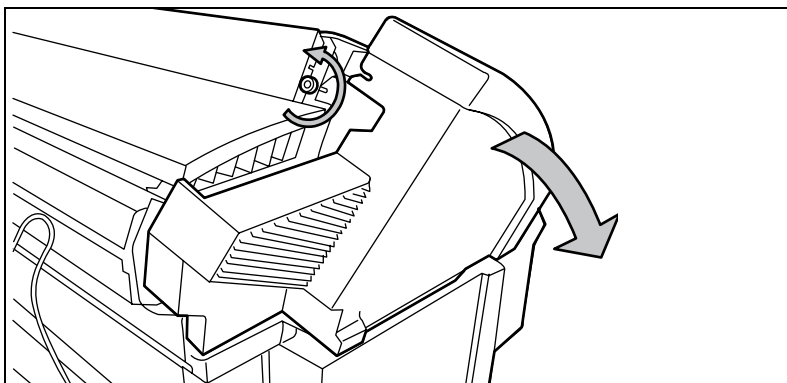

[15] Unscrewing the access nut and opening the cover

- 2 Shake the toner bottle thoroughly and then open it.
- 3 Screw the bottle in clockwise, in a slanted position (see figure 16).

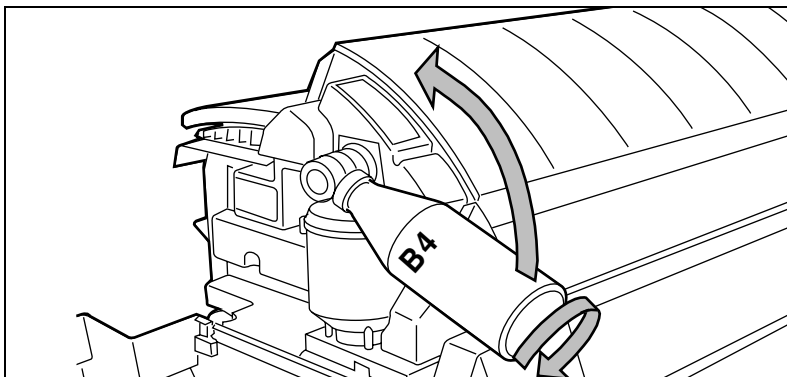

[16] Screwing the bottle into place

- 4 Move the toner bottle to a vertical position (see figure 16) and 17).

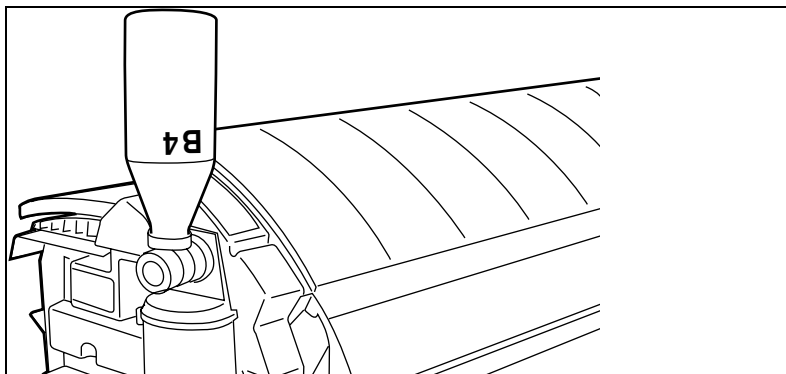

[17] Adding toner

- 5 Empty the toner out of the bottle by tapping it.
- 6 When the toner bottle is completely empty, return it to its original position.
- 7 Unscrew the toner bottle, turning it counter-clockwise.

▼ Replacing the waste toner bag

- 8 Pull the waste toner bag from the holder and seal the bag with the cap provided (see figure 18).

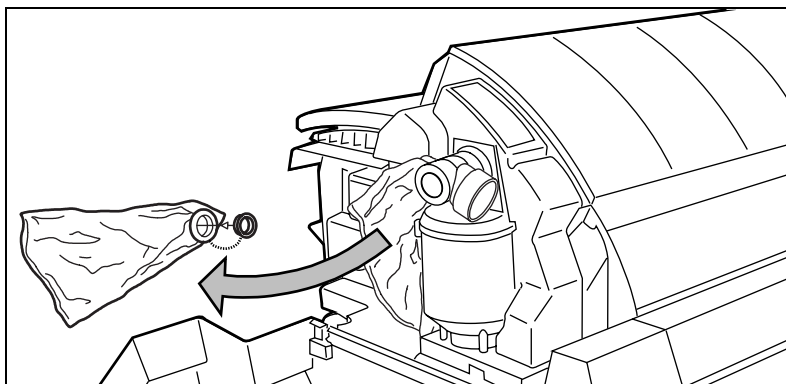

[18] Replacing the waste toner bag

- 9 Slide a new waste toner bag over the holder.
- 10 Close the cover and tighten the access nut.
- 11 Press the 'Continue' button to resume printing.

Chapter 4

Printing files

This chapter describes how to print files.



Printing files

The Océ 9300 can be connected to a host environment, which may be either a stand alone PC/Workstation or a PC/Workstation connected to a network. It accepts various standard format CAD/CAM vector and EDMS raster data files from the host environment and converts these into high quality plots (see figure 19).

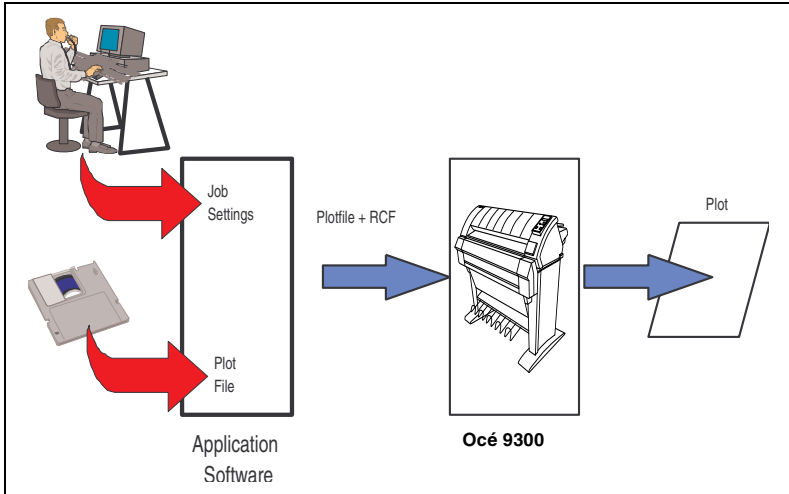

[19] Data flow to the Océ 9300

When an Océ 9300 receives vector (HP-GL, HP-GL/2, VDF, BGL, Calcomp 906/907), raster (HP-RTL, TIFF, CALS) or PostScript (PostScript level 2 optional) data, it generates a plot using the settings (e.g. number of copies, plotter emulation, etc.) specified on the operator console in Program Mode.

For maximum flexibility, each plot job can be preceded by remote-control commands specifying the settings to be used for that specific job. These commands are contained in a 'header' containing job- and file-specific settings (e.g. number of copies), in Remote Control Format (RCF), which override the settings programmed in Program Mode.

You may use the following methods to compose a header of this type:

- Compose the header within your application. Please see the RCF manual for details about the RCF syntax and functionality.
- An Océ Windows or Autocad ADI driver can be used to generate both a plottable file (e.g. HP-RTL, HP-GL/2) and the appropriate header with RCF commands. Refer to the Océ Windows / Autocad Driver documentation for further details.
- The Océ Windows Plot Director application allows you to compose jobs containing plottable files in a very flexible and user-friendly way. Refer to the Océ Plot Director manual for further details.

Océ application

The following application is available:

Plot Director (MS-Windows 3.x, 95/98 and NT)

Océ drivers

Note: *Please refer to the Océ website (www.oce.com) for obtaining the latest drivers.*

ADI driver for AutoCAD R13C3 (Windows 95/98),

ADI driver for AutoCAD R13C4 (MS-DOS, Windows 95/98, NT 4.0),

ADI driver for AutoCAD R14 (Windows 95/98, NT 4.0),

HDI driver for AutoCad 2000 (Windows 95/98 and NT 4.0),

AutoCad LT: use a window system driver provided by Océ (e.g.; Windows Raster Driver),

Windows Raster Driver (Windows 95/98 and NT),

PostScript driver (Windows 95/98, NT and Macintosh).

Cut method

This setting can be used to select standard cut or synchro cut.

Note: *Use Synchro Cut when you have to define a non-standard paper size in your application.*

The values selected for leading or trailing edge are taken into account when using Synchro Cut.

▼ Programming cut method

- 1 Press 'Program' to enter the main menu.
- 2 Select 'MEDIA SETTING' item using the ◀ or ▶ button.
- 3 Press 'next/select' to enter the 'MEDIA SETTING' menu.
- 4 Select the 'PLOT POSITION' item using the ◀ or ▶ button.
- 5 Press 'next/select' to enter the 'PLOT POSITION' menu.
- 6 Select the 'CUT METHOD' item using the ◀ or ▶ button.
- 7 Press 'next/select' to enter the 'CUT METHOD' menu.
- 8 Select the desired cut method using the ◀ or ▶ button.
- 9 Press 'next/select' to confirm the selected cut method.
- 10 Press 'Program' to exit the main menu.

Plot Center

This setting can be used to enable or disable centering of the plot on the paper. If the center setting is disabled, the plot will be positioned in the upper left-hand corner of the page.

If Standard Cut is selected, the plot is printed and the media is cut according to the standard cut functionality. If Plot Center is ON, the plot is shifted up/down and left/right to be centered on the selected bounding box.

Note: *If you print a plot that exceeds standard length, the machine automatically switches to synchro cut to prevent you from losing information.*

If Synchro Cut is selected, the bounding box of the plot sets hard clip limits. If Plot Center is ON, the plot is shifted left/right to be centered on the page.

▼ **Programming Plot Center**

- 1 Press 'Program' to enter the main menu.
- 2 Select 'MEDIA SETTING' item using the ◀ or ▶ button.
- 3 Press 'next/select' to enter the 'MEDIA SETTING' menu.
- 4 Select the 'PLOT POSITION' item using the ◀ or ▶ button.
- 5 Press 'next/select' to enter the 'PLOT POSITION' menu.
- 6 Select the 'PLOT CENTER' item using the ◀ or ▶ button.
- 7 Press 'next/select' to enter the 'PLOT CENTER' menu.
- 8 Select the 'ON/OFF' using the ◀ or ▶ button.
- 9 Press 'next/select' to confirm the setting.
- 10 Press 'Program' to exit the main menu.

Leading/trailing edge

The leading edge setting can be used to add a white strip at the top of the image. The page length will increase accordingly.

The trailing edge setting can be used to add a white strip at the end of the image. The page length will increase accordingly.

Note: *The leading/trailing edge option only works if the cut method is set to synchro cut.*

The value for the trailing or leading edge can be set from 0 to 80 mm (in increments of 5 mm) or 0 to +3 inch (in increments of 1/4 inch).

▼ **Programming leading or trailing edge**

- 1 Press 'Program' to enter the main menu.
- 2 Select 'MEDIA SETTING' item using the ◀ or ▶ button.
- 3 Press 'next/select' to enter the 'MEDIA SETTING' menu.
- 4 Select the 'PLOT POSITION' item using the ◀ or ▶ button.
- 5 Press 'next/select' to enter the 'PLOT POSITION' menu.
- 6 Select the 'TRAILING' or 'LEADING EDGE' item using the ◀ or ▶ button.
- 7 Press 'next/select' to enter the 'TRAILING' or 'LEADING EDGE' menu.
- 8 Select the required value using the ◀ or ▶ button.
- 9 Press 'next/select' to confirm the value.
- 10 Press 'Program' to exit the main menu.

Demo plot

After installing the Océ 9300, we recommend that you generate a demo plot in order to make sure that the printer works properly.

▼ **Making a demo plot**

- 1 Press 'Program' to enter the main menu.
- 2 Select the 'PLOT' item using the ◀ or ▶ button.
- 3 Press 'next/select' to enter the 'PLOT' menu.
- 4 Select the 'DEMO PLOT' item using the ◀ or ▶ button.
- 5 Press 'next/select' to print the demo plot.
- 6 Press 'Program' to exit the main menu.

Cancel plot

If you want to cancel a plot before printing starts:

▼ **Cancelling a plot**

- 1 Press 'cancel/continue'.
The printer will stop. Printing of the plot may be discontinued.
The print media is always ejected.

Chapter 5

Customizing defaults

This chapter explains how to set certain Océ 9300 defaults, such as pen settings and languages, to accommodate frequently-used print jobs.



Defining pen settings

You can change the pen settings for the files you want to print in the pen menu. The default width and pattern for each pen number can be changed in this menu. These settings apply to all vector languages: HP-GL, HP-GL/2, CalComp.

Pen width can be defined from 0.08 up to 10.75 mm (0.0031" to 0.423"). All pen widths are set to 0.25 mm (0.009") by default. Adjustments can be made in increments of 0.01 mm.

A pen can be selected by the plot file to draw a line or to fill a polygon. All lines or polygons on the plot can be drawn with a predefined pattern or shade of gray. Pen pattern 16 is the default. The following pen patterns are available:

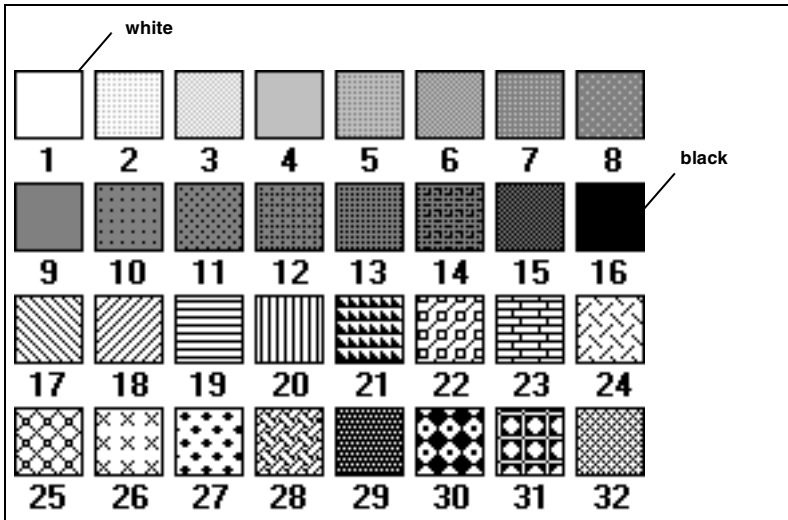

[20] Available pen patterns



Defining the pen settings

- 1 Press 'Program' to enter the main menu.
- 2 Select the 'CONFIGURATION' item using the ◀ or ▶ button.
- 3 Press 'next/select' to enter the 'CONFIGURATION' menu.
- 4 Select the 'PEN MENU' option using the ◀ or ▶ button.
- 1 Press 'next/select' to enter the 'PEN MENU'.

For each pen setup, proceed as follows:

- 2 Select the 'PEN NUMBER' item using the ◀ or ▶ button.
- 3 Press 'next/select' to enter the 'PEN NUMBER' menu.
- 4 Select the required 'PEN NUMBER' using the ◀ or ▶ button.
- 5 Press 'next/select' to confirm the selected pen number.
- 6 Press 'previous' to re-enter the pen menu.

From this menu:

- 7 Select the 'PEN WIDTH' item using the ◀ or ▶ button.
- 8 Press 'next/select' to enter the 'PEN WIDTH' menu.
- 9 Select the required pen width using the ◀ or ▶ button.
- 10 Press 'next/select' to confirm the selected pen width.
- 11 Press 'previous' to re-enter the pen menu.
- 12 Select the 'PEN PATTERN' item using the ◀ or ▶ button.
- 13 Press 'next/select' to enter the 'PEN PATTERN' menu.
- 14 Select the appropriate pen pattern using the ◀ or ▶ button.
- 15 Press 'next/select' to confirm the selected pen pattern.

After programming all pen settings:

- 16 Press 'Program' to exit the main menu.

Defining language settings

The Océ 9300 accepts print files in various data formats (languages). You can change the settings for PostScript, VDF, BGL, HP-GL, HP-GL/2, HP-RTL, CalComp, CALS, TIFF or EDMICS.

Automatic language sensing

Automatic language sensing (ALS) is the mechanism which the system uses to detect the language (data format) of a file for which the format has not been specified in the file header. ALS scans the file contents for clues about the data format. Automatic language sensing can be switched on/off. By default, ALS is activated.

ALS enables the printer to switch between the following languages:

- Océ languages (VDF and BGL), PostScript, HP-GL, HP-GL/2, HP-RTL, CalComp, CALS, TIFF or EDMICS

Use the ALS formats parameter to define which data formats are to be searched for in the print files.

Note: *When using ALS, it is very important that every print file end with an end-of-print instruction.*

▼ **Activating ALS**

- 1 Press 'Program' to enter the main menu.
- 2 Select the 'CONFIGURATION' item using the ◀ or ▶ button.
- 3 Press 'next/select' to enter the 'CONFIGURATION' menu.
- 4 Select the 'DATA FORMAT' item using the ◀ or ▶ button.
- 5 Press 'next/select' to enter the 'DATA FORMAT' menu.
- 6 Select the 'SELECT FORMAT' item using the ◀ or ▶ button.
- 7 Press 'next/select' to enter the 'SELECT FORMAT' menu.
- 8 Select the 'AUTO' item using the ◀ or ▶ button.
- 9 Press 'next/select' to set up this mode.
- 10 Press 'Program' to exit the main menu.

Data format recognition

To optimize your printer's language recognition capabilities and reduce the risk of errors, each of the above-mentioned data formats can be individually set 'ON' or 'OFF'. The default is 'ON'.

▼ **Optimizing data format recognition**

- 1 Press 'Program' to enter the main menu.
- 2 Select the 'CONFIGURATION' item using the ◀ or ▶ button.
- 3 Press 'next/select' to enter the 'CONFIGURATION' menu.
- 4 Select the 'DATA FORMAT' item using the ◀ or ▶ button.
- 5 Press 'next/select' to enter the 'DATA FORMAT' menu.
- 6 Select the 'AUTO MENU' item using the ◀ or ▶ button.
- 7 Press 'next/select' to enter the 'AUTO MENU' menu.
For each graphics language setup, proceed as follows:
- 8 Select the required 'GRAPHICS LANGUAGE' item using the ◀ or ▶ button.
- 9 Press 'next/select' to enter the required language menu.
- 10 Select 'YES' or 'NO' using the ◀ or ▶ button.
- 11 Press 'next/select' to confirm the selected setting.
- 12 Press 'previous' to re-enter the 'GRAPHICS LANGUAGE' menu.
After programming all languages:
- 13 Press 'Program' to exit the main menu.

Manual data format selection

If necessary, each of the data formats can be selected manually.

Note: *In this case, ALS is inactive.*

▼ **Setting manual data format**

- 1 Press 'Program' to enter the main menu.
- 2 Select the 'CONFIGURATION' item using the ◀ or ▶ button.
- 3 Press 'next/select' to enter the 'CONFIGURATION' menu.
- 4 Select the 'DATA FORMAT' item using the ◀ or ▶ button.
- 5 Press 'next/select' to enter the 'DATA FORMAT' menu.
- 6 Select the 'SELECT FORMAT' item using the ◀ or ▶ button.
- 7 Press 'next/select' to enter the 'SELECT FORMAT' menu.
- 8 Select the required language using the ◀ or ▶ button.
- 9 Press 'next/select' to confirm the selected language.
- 10 Press 'Program' to exit the main menu.

Note: *When PostScript is selected, RCF headers are not recognized.*

Océ languages (VDF/BGL)

Océ print origin

The term “print origin” refers to the point on the paper at which printing starts. You can choose among the following options: Upper right, upper left, center, lower right and lower left (see figure 21). The default is lower right.

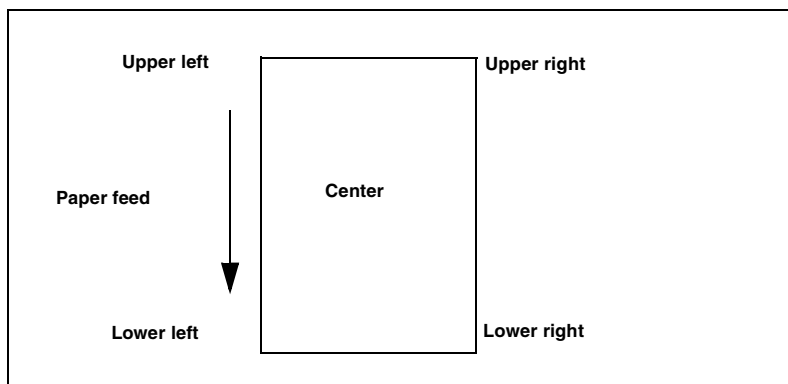

[21] Print origin options

▼ Defining the print origin

- 1 Press ‘Program’ to enter the main menu.
- 2 Select the ‘CONFIGURATION’ item using the ◀ or ▶ button.
- 3 Press ‘next/select’ to enter the ‘CONFIGURATION’ menu.
- 4 Select the ‘DATA FORMAT’ item using the ◀ or ▶ button.
- 5 Press ‘next/select’ to enter the ‘DATA FORMAT’ menu.
- 6 Select the ‘OCE SETUP’ item using the ◀ or ▶ button.
- 7 Press ‘next/select’ to enter the ‘OCE SETUP’ menu.
- 8 Select the ‘ORIGIN’ item using the ◀ or ▶ button.
- 9 Press ‘next/select’ to enter the ‘ORIGIN’ menu.
- 10 Select the required origin using the ◀ or ▶ button.
- 11 Press ‘next/select’ to confirm the selected origin.
- 12 Press ‘Program’ to exit the main menu.

Océ step size

The Océ 9300 offers four different step sizes: 12.5 μm , 25 μm , 50 μm and 100 μm (see figure 22). Be careful when choosing the step size: the wrong step size will negatively affect the scale of your drawing. The default is 25.

For example: Drawing A was printed with 50 μm step size as defined in the software. The scale is correct.

Drawing B shows the same drawing printed with 100 μm step size. The print is twice its normal size.

Drawing C shows the same drawing printed with 25 μm step size. The print is half its normal size.

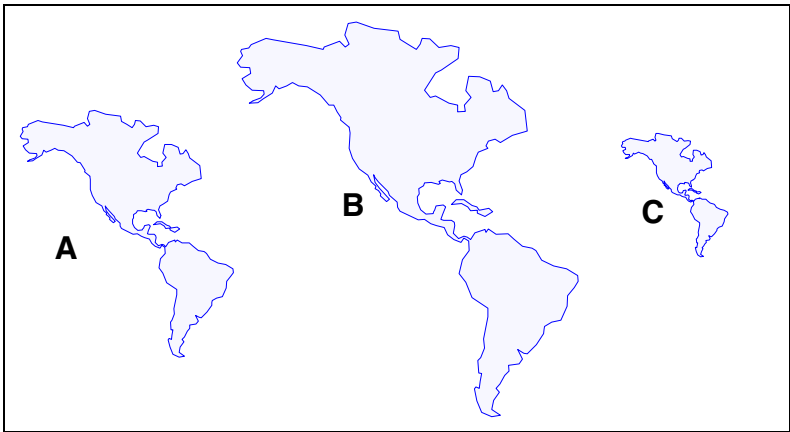

[22] Step size

▼ Defining the step size

- 1 Press 'Program' to enter the main menu.
- 2 Select the 'CONFIGURATION' item using the ◀ or ▶ button.
- 3 Press 'next/select' to enter the 'CONFIGURATION' menu.
- 4 Select the 'DATA FORMAT' item using the ◀ or ▶ button.
- 5 Press 'next/select' to enter the 'DATA FORMAT' menu.
- 6 Select the 'OCE SETUP' item using the ◀ or ▶ button.
- 7 Press 'next/select' to enter the 'OCE SETUP' menu.
- 8 Select the 'STEP SIZE' item using the ◀ or ▶ button.
- 9 Press 'next/select' to enter the 'STEP SIZE' menu.
- 10 Select the required step size using the ◀ or ▶ button.

- 11 Press 'next/select' to confirm the selected value.
- 12 Press 'Program' to exit the main menu.

Océ pen priority

You can define pen parameters in the print file, either in a remote configuration file or from the printer control panel. The pen priority option allows you to define which set of pen parameters you want to use. The default is Language.

If **Language** is selected, the pen parameters defined in the data file will be used. If **Setup** is selected, the pen parameter defined on the printer operating panel, or in the optional remote configuration file, will be used.



Defining Océ pen priority

- 1 Press 'Program' to enter the main menu.
- 2 Select the 'CONFIGURATION' item using the ◀ or ▶ button.
- 3 Press 'next/select' to enter the 'CONFIGURATION' menu.
- 4 Select the 'DATA FORMAT' item using the ◀ or ▶ button.
- 5 Press 'next/select' to enter the 'DATA FORMAT' menu.
- 6 Select the 'OCE SETUP' item using the ◀ or ▶ button.
- 7 Press 'next/select' to enter the 'OCE SETUP' menu.
- 8 Select the 'PEN PRIORITY' item using the ◀ or ▶ button.
- 9 Press 'next/select' to enter the 'PEN PRIORITY' menu.
- 10 Select the required pen width using the ◀ or ▶ button.
- 11 Press 'next/select' to confirm the selected pen priority.
- 12 Press 'Program' to exit the main menu.

HP-GL

This function allows you to define settings for HP-GL file types.

HP-GL print origin

The term “print origin” refers to the point on the paper at which printing starts. You can choose among the following options: Upper right, upper left, center, lower right and lower left. The default is center.

▼ Defining the HP-GL print origin

- 1 Press ‘Program’ to enter the main menu.
- 2 Select the ‘CONFIGURATION’ item using the ◀ or ▶ button.
- 3 Press ‘next/select’ to enter the ‘CONFIGURATION’ menu.
- 4 Select the ‘DATA FORMAT’ item using the ◀ or ▶ button.
- 5 Press ‘next/select’ to enter the ‘DATA FORMAT’ menu.
- 6 Select the ‘HP-GL SETUP’ item using the ◀ or ▶ button.
- 7 Press ‘next/select’ to enter the ‘HP-GL SETUP’ menu.
- 8 Select the ‘ORIGIN’ item using the ◀ or ▶ button.
- 9 Press ‘next/select’ to enter the ‘ORIGIN’ menu.
- 10 Select the required origin using the ◀ or ▶ button.
- 11 Press ‘next/select’ to confirm the selected origin.
- 12 Press ‘Program’ to exit the main menu.

HP-GL page advance

The Select Pen Zero (SP0) command in HP-GL can be interpreted in two ways:

If ‘PAGE ADVANCE’ is set to **yes**, the printer responds to the HP-GL instruction SP0 as an indication of end of print.

If ‘PAGE ADVANCE’ is set to **no**, the printer responds to the HP-GL instruction SP0 as select pen zero. Any vectors following the SP0 will be printed with the defined pen attributes (width and pattern). The default is Yes. See also ‘Defining pen settings’ on page 46.

▼ **Setting the HP-GL page advance**

- 1 Press 'Program' to enter the main menu.
- 2 Select the 'CONFIGURATION' item using the ◀ or ▶ button.
- 3 Press 'next/select' to enter the 'CONFIGURATION' menu.
- 4 Select the 'DATA FORMAT' item using the ◀ or ▶ button.
- 5 Press 'next/select' to enter the 'DATA FORMAT' menu.
- 6 Select the 'HP-GL SETUP' item using the ◀ or ▶ button.
- 7 Press 'next/select' to enter the 'HP-GL SETUP' menu.
- 8 Select the required 'PAGE ADVANCE' item using the ◀ or ▶ button.
- 9 Press 'next/select' to enter the 'PAGE ADVANCE' menu.
- 10 Select 'YES' or 'NO' using the ◀ or ▶ button.
- 11 Press 'next/select' to confirm the selected setting.
- 12 Press 'Program' to exit the main menu.

Merge mode

This option determines what happens when two or more colors intersect at the same point of a plot, especially in area fills. This option is On by default.

Merge Off Only the last color specified is printed for a given line or area. The other colors specified for the same line or area are transparent.

Merge On All the specified colors are blended together.

▼ **Setting the merge mode**

- 1 Press 'Program' to enter the main menu.
- 2 Select the 'CONFIGURATION' item using the ◀ or ▶ button.
- 3 Press 'next/select' to enter the 'CONFIGURATION' menu.
- 4 Select the 'DATA FORMAT' item using the ◀ or ▶ button.
- 5 Press 'next/select' to enter the 'DATA FORMAT' menu.
- 6 Select the 'HP-GL SETUP' item using the ◀ or ▶ button.
- 7 Press 'next/select' to enter the 'HP-GL SETUP' menu.
- 8 Select the 'MERGE' item using the ◀ or ▶ button.
- 9 Press 'next/select' to enter the 'MERGE' menu.
- 10 Select 'YES' or 'NO' using the ◀ or ▶ button.
- 11 Press 'next/select' to confirm the selected setting.
- 12 Press 'Program' to exit the main menu.

HP-GL/2

HP-GL/2 print origin

The term “print origin” refers to the point on the paper at which printing starts. You can choose among the following options: Upper right, upper left, center, lower right and lower left. The default is lower right.

▼ Defining the HP-GL/2 print origin

- 1 Press ‘Program’ to enter the main menu.
- 2 Select the ‘CONFIGURATION’ item using the ◀ or ▶ button.
- 3 Press ‘next/select’ to enter the ‘CONFIGURATION’ menu.
- 4 Select the ‘DATA FORMAT’ item using the ◀ or ▶ button.
- 5 Press ‘next/select’ to enter the ‘DATA FORMAT’ menu.
- 6 Select the ‘HP-GL/2 SETUP’ item using the ◀ or ▶ button.
- 7 Press ‘next/select’ to enter the ‘HP-GL/2 SETUP’ menu.
- 8 Select the ‘ORIGIN’ item using the ◀ or ▶ button.
- 9 Press ‘next/select’ to enter the ‘ORIGIN’ menu.
- 10 Select the required origin item using the ◀ or ▶ button.
- 11 Press ‘next/select’ to confirm the selected origin.
- 12 Press ‘Program’ to exit the main menu.

HP-GL/2 page advance

The SP0 command in HP-GL/2 can be interpreted in two ways, depending on the printer being emulated.

If ‘PAGE ADVANCE’ is set to **yes**, the printer responds to the HP-GL instruction SP0 as an indication of end of print.

If ‘PAGE ADVANCE’ is set to **no**, the printer responds to the HP-GL instruction SP0 as select pen zero. Any vectors following the SP0 will be printed with the defined pen attributes (width and pattern). The default is No. See also ‘Defining pen settings’ on page 46.

▼ **Setting the HP-GL/2 page advance**

- 1 Press 'Program' to enter the main menu.
- 2 Select the 'CONFIGURATION' item using the ◀ or ▶ button.
- 3 Press 'next/select' to enter the 'CONFIGURATION' menu.
- 4 Select the 'DATA FORMAT' item using the ◀ or ▶ button.
- 5 Press 'next/select' to enter the 'DATA FORMAT' menu.
- 6 Select the 'HP-GL/2 SETUP' item using the ◀ or ▶ button.
- 7 Press 'next/select' to enter the 'HP-GL/2 SETUP' menu.
- 8 Select the 'PAGE ADVANCE' item using the ◀ or ▶ button.
- 9 Press 'next/select' to enter the 'PAGE ADVANCE' menu.
- 10 Select the required page advance using the ◀ or ▶ button.
- 11 Press 'next/select' to confirm the selected page advance.
- 12 Press 'Program' to exit the main menu.

HP-GL/2 pen priority

You can define pen parameters in the print file, either in a remote configuration file or from the printer control panel. The pen priority option allows you to define which set of pen parameters you want to use.

If '**Language**' is selected, the pen parameters defined in the data file will be used. If '**Setup**' is selected, the pen parameter defined on the printer operating panel, or in the optional remote configuration file, will be used. The default is 'Language'.

▼ **Defining HP-GL/2 pen priority**

- 1 Press 'Program' to enter the main menu.
- 2 Select the 'CONFIGURATION' item using the ◀ or ▶ button.
- 3 Press 'next/select' to enter the 'CONFIGURATION' menu.
- 4 Select the 'DATA FORMAT' item using the ◀ or ▶ button.
- 5 Press 'next/select' to enter the 'DATA FORMAT' menu.
- 6 Select the 'HP-GL/2 SETUP' item using the ◀ or ▶ button.
- 7 Press 'next/select' to enter the 'HP-GL/2 SETUP' menu.
- 8 Select the 'PEN PRIORITY' item using the ◀ or ▶ button.
- 9 Press 'next/select' to enter the 'PEN PRIORITY' menu.
- 10 Select the required pen priority using the ◀ or ▶ button.
- 11 Press 'next/select' to confirm the selected pen priority.
- 12 Press 'Program' to exit the main menu.

Designjet compatibility

If you print a color data file on a black-and-white printer, the result may not be satisfactory. If you emulate the HP 650C, all information which is defined in color is printed in black; if you emulate the HP 750C, all information which is defined in color will be printed in gray-scale levels.

▼ Defining Designjet compatibility

- 1 Press 'Program' to enter the main menu.
- 2 Select the 'CONFIGURATION' item using the ◀ or ▶ button.
- 3 Press 'next/select' to enter the 'CONFIGURATION' menu.
- 4 Select the 'DATA FORMAT' item using the ◀ or ▶ button.
- 5 Press 'next/select' to enter the 'DATA FORMAT' menu.
- 6 Select the 'HP-GL/2 SETUP' item using the ◀ or ▶ button.
- 7 Press 'next/select' to enter the 'HP-GL SETUP' menu.
- 8 Select the 'DESIGNJET' item using the ◀ or ▶ button.
- 9 Press 'next/select' to enter the 'DESIGNJET' menu.
- 10 Select the required Designjet using the ◀ or ▶ button.
- 11 Press 'next/select' to confirm the selected Designjet.
- 12 Press 'Program' to exit the main menu.

Merge mode

This option determines what happens when two or more colors intersect at the same point of a plot, especially in area fills. This option is On by default.

Merge Off Only the last color specified is printed for a given line or area. The other colors specified for the same line or area are transparent.

Merge On All the specified colors are blended together.

▼ Setting the merge mode

- 1 Press 'Program' to enter the main menu.
- 2 Select the 'CONFIGURATION' item using the ◀ or ▶ button.
- 3 Press 'next/select' to enter the 'CONFIGURATION' menu.
- 4 Select the 'DATA FORMAT' item using the ◀ or ▶ button.
- 5 Press 'next/select' to enter the 'DATA FORMAT' menu.
- 6 Select the 'HP-GL/2 SETUP' item using the ◀ or ▶ button.
- 7 Press 'next/select' to enter the 'HP-GL/2 SETUP' menu.
- 8 Select the 'MERGE' item using the ◀ or ▶ button.

- 9 Press 'next/select' to enter the 'MERGE' menu.
- 10 Select 'YES' or 'NO' using the ◀ or ▶ button.
- 11 Press 'next/select' to confirm the selected setting.
- 12 Press 'Program' to exit the main menu.

Line Attribute

This option determines whether the ends of the vectors are rounded or printed as on an HP machine. The default setting is Océ round.

Océ round prints all vector ends and joins rounded.

HP default prints the vector ends and joins according to the HP standard.



Setting the line attributes

- 1 Press 'Program' to enter the main menu.
- 2 Select the 'CONFIGURATION' item using the ◀ or ▶ button.
- 3 Press 'next/select' to enter the 'CONFIGURATION' menu.
- 4 Select the 'DATA FORMAT' item using the ◀ or ▶ button.
- 5 Press 'next/select' to enter the 'DATA FORMAT' menu.
- 6 Select the 'HP-GL/2 SETUP' item using the ◀ or ▶ button.
- 7 Press 'next/select' to enter the 'HP-GL/2 SETUP' menu.
- 8 Select the 'LINE ATTRIBUTE' item using the ◀ or ▶ button.
- 9 Press 'next/select' to enter the 'LINE ATTRIBUTE' menu.
- 10 Select 'OCE ROUND' or 'HP DEFAULT' using the ◀ or ▶ button.
- 11 Press 'next/select' to confirm the selected setting.
- 12 Press 'Program' to leave the main menu.

HP-RTL

HP-RTL is a subset of HP-GL/2. Therefore, all HP-RTL plot data files must start with ESC%-1BBPIN: or BPIN.

To use HP-RTL, the SELECT FORMAT should be set to AUTO or HP-GL/2 on the operating panel or HP-GL/2 must be selected via a remote control file.

Note: *HP-RTL plot data files must end with ESC%OB; PG; which will switch the printer back to HP-GL/2 format mode. Without this command, the plot results will be unpredictable and the printer will stop.*

The following HP-RTL statements are not recognized by the Océ 9300 and will be treated as no-ops: ESC*v#a, ESC*v#b, ESC*v#c, ESC*v#i, ESC*v#W[data], ESC*b#1 and ESC&b#V[data].

CalComp

The Océ 9300 supports use of the CalComp graphics language.

CalComp print origin

The term “print origin” refers to the point on the paper at which a drawing starts: Upper right, upper left, center, lower right and lower left.

The default CalComp origin is lower right. This print origin is used for all CalComp files, whether the format is set to CalComp or Auto, even if a remote control command for CalComp is sent.

▼ Defining the print origin

- 1 Press ‘Program’ to enter the main menu.
- 2 Select the ‘CONFIGURATION’ item using the ◀ or ▶ button.
- 3 Press ‘next/select’ to enter the ‘CONFIGURATION’ menu.
- 4 Select the ‘DATA FORMAT’ item using the ◀ or ▶ button.
- 5 Press ‘next/select’ to enter the ‘DATA FORMAT’ menu.
- 6 Select the ‘CALCOMP SETUP’ item using the ◀ or ▶ button.
- 7 Press ‘next/select’ to enter the ‘CALCOMP SETUP’ menu.
- 8 Select the ‘ORIGIN’ item using the ◀ or ▶ button.
- 9 Press ‘next/select’ to enter the ‘ORIGIN’ menu.
- 10 Select the required origin item using the ◀ or ▶ button.
- 11 Press ‘next/select’ to confirm the selected origin.
- 12 Press ‘Program’ to exit the main menu.

Checksum parameter

The checksum parameter is significant in all cases in which the CalComp format is selected or auto-recognized, and select format is set to Auto or a remote control command for CalComp has been sent. The default is Yes.

▼ Defining the checksum parameter

- 1 Press 'Program' to enter the main menu.
- 2 Select the 'CONFIGURATION' item using the ◀ or ▶ button.
- 3 Press 'next/select' to enter the 'CONFIGURATION' menu.
- 4 Select the 'DATA FORMAT' item using the ◀ or ▶ button.
- 5 Press 'next/select' to enter the 'DATA FORMAT' menu.
- 6 Select the 'CALCOMP SETUP' item using the ◀ or ▶ button.
- 7 Press 'next/select' to enter the 'CALCOMP SETUP' menu.
- 8 Select the 'CHECKSUM' item using the ◀ or ▶ button.
- 9 Press 'next/select' to enter the 'CHECKSUM' menu.
- 10 Select 'YES' or 'NO' using the ◀ or ▶ button.
- 11 Press 'next/select' to confirm the selected setting.
- 12 Press 'Program' to exit the main menu.

CalComp pen priority

You can define pen parameters in the print file, either in a remote configuration file or from the printer control panel. The pen priority option allows you to define which set of pen parameters you want to use.

If '**Language**' is selected, the pen parameters defined in the data file will be used. If '**Setup**' is selected, the pen parameter defined on the printer operating panel, or in the optional remote configuration file, will be used. The default is Language.

- 1 Press 'Program' to enter the main menu.
- 2 Select the 'CONFIGURATION' item using the ◀ or ▶ button.
- 3 Press 'next/select' to enter the 'CONFIGURATION' menu.
- 4 Select the 'DATA FORMAT' item using the ◀ or ▶ button.
- 5 Press 'next/select' to enter the 'DATA FORMAT' menu.
- 6 Select the 'CALCOMP SETUP' item using the ◀ or ▶ button.
- 7 Press 'next/select' to enter the 'CALCOMP SETUP' menu.
- 8 Select the 'PEN PRIORITY' item using the ◀ or ▶ button.
- 9 Press 'next/select' to enter the 'PEN PRIORITY' menu.

- 10 Select the required pen priority using the ◀ or ▶ button.
- 11 Press 'next/select' to confirm the selected pen priority.
- 12 Press 'Program' to exit the main menu

Merge mode

This option determines what happens when two or more colors intersect at the same point of a plot, especially in area fills. The default setting is 'On'.

Merge Off Only the last color specified is printed for a given line or area. The other colors specified for the same line or area are transparent.

Merge On All the specified colors are blended together.

▼ Setting the merge mode

- 1 Press 'Program' to enter the main menu.
- 2 Select the 'CONFIGURATION' item using the ◀ or ▶ button.
- 3 Press 'next/select' to enter the 'CONFIGURATION' menu.
- 4 Select the 'DATA FORMAT' item using the ◀ or ▶ button.
- 5 Press 'next/select' to enter the 'DATA FORMAT' menu.
- 6 Select the 'CALCOMP SETUP' item using the ◀ or ▶ button.
- 7 Press 'next/select' to enter the 'CALCOMP SETUP' menu.
- 8 Select the 'MERGE' item using the ◀ or ▶ button.
- 9 Press 'next/select' to enter the 'MERGE' menu.
- 10 Select 'YES' or 'NO' using the ◀ or ▶ button.
- 11 Press 'next/select' to confirm the selected setting.
- 12 Press 'Program' to exit the main menu.

End of Message parameter

The End of Message (EOM) parameter is significant in all cases in which the CalComp format is selected or auto-recognized, and select format is set to Auto or a remote control command for CalComp has been sent.

The range of permitted values is 0 to 31_{DEC} inclusive. The selected value is the decimal equivalent of the byte indicating the end of the data sequence. It should be a unique character from the character set used to encode the data. The default EOM is 3.

▼ **Setting the End of Message parameter**

- 1 Press 'Program' to enter the main menu.
- 2 Select the 'CONFIGURATION' item using the ◀ or ▶ button.
- 3 Press 'next/select' to enter the 'CONFIGURATION' menu.
- 4 Select the 'DATA FORMAT' item using the ◀ or ▶ button.
- 5 Press 'next/select' to enter the 'DATA FORMAT' menu.
- 6 Select the 'CALCOMP SETUP' item using the ◀ or ▶ button.
- 7 Press 'next/select' to enter the 'CALCOMP SETUP' menu.
- 8 Select the 'END OF MESSAGE' item using the ◀ or ▶ button.
- 9 Press 'next/select' to enter the 'END OF MESSAGE' menu.
- 10 Select the required value using the ◀ or ▶ button.
- 11 Press 'next/select' to confirm the selected value.
- 12 Press 'Program' to exit the main menu.

Synchronization code parameter

The synchronization code parameter is significant in all cases in which CalComp format is selected or auto-recognized, when select format is set to Auto or a remote control command for CalComp has been sent.

The range of permitted values is 0 to 63_{DEC} inclusive. The selected value is the decimal equivalent of the byte interpreted as the beginning of a print data block. The default synchronization code is 2.

▼ **Setting the synchronization code parameter**

- 1 Press 'Program' to enter the main menu.
- 2 Select the 'CONFIGURATION' item using the ◀ or ▶ button.
- 3 Press 'next/select' to enter the 'CONFIGURATION' menu.
- 4 Select the 'DATA FORMAT' item using the ◀ or ▶ button.
- 5 Press 'next/select' to enter the 'DATA FORMAT' menu.
- 6 Select the 'CALCOMP SETUP' item using the ◀ or ▶ button.
- 7 Press 'next/select' to enter the 'CALCOMP SETUP' menu.
- 8 Select the 'SYNC CODE' item using the ◀ or ▶ button.
- 9 Press 'next/select' to enter the 'SYNC CODE' menu.
- 10 Select the required sync code using the ◀ or ▶ button.
- 11 Press 'next/select' to confirm the selected sync code.
- 12 Press 'Program' to exit the main menu.

Double synchronization code parameter

The synchronization code parameter is significant in all cases in which CalComp format is selected or auto-recognized, when select format is set to Auto or a remote control command for CalComp has been sent.

The double synchronization parameter allows one or two synchronization characters to identify the beginning of a message of print data. If set to double synchronization, the same character is sent twice. The default is 'No'.

▼ **Setting the double synchronization code parameter**

- 1 Press 'Program' to enter the main menu.
- 2 Select the 'CONFIGURATION' item using the ◀ or ▶ button.
- 3 Press 'next/select' to enter the 'CONFIGURATION' menu.
- 4 Select the 'DATA FORMAT' item using the ◀ or ▶ button.
- 5 Press 'next/select' to enter the 'DATA FORMAT' menu.
- 6 Select the 'CALCOMP SETUP' item using the ◀ or ▶ button.
- 7 Press 'next/select' to enter the 'CALCOMP SETUP' menu.
- 8 Select the 'DOUBLE SYNC' item using the ◀ or ▶ button.
- 9 Press 'next/select' to enter the 'DOUBLE SYNC' menu.
- 10 Select the required double sync using the ◀ or ▶ button.
- 11 Press 'next/select' to confirm the selected value.
- 12 Press 'Program' to exit the main menu.

CalComp step size

If the data format type is set to CalComp (manual, auto selection, or remote control command), seven steps or increments are provided (100 dpi to 4064 dpi). The default is 2032.

▼ **Setting the appropriate step size**

- 1 Press 'Program' to enter the main menu.
- 2 Select the 'CONFIGURATION' item using the ◀ or ▶ button.
- 3 Press 'next/select' to enter the 'CONFIGURATION' menu.
- 4 Select the 'DATA FORMAT' item using the ◀ or ▶ button.
- 5 Press 'next/select' to enter the 'DATA FORMAT' menu.
- 6 Select the 'CALCOMP SETUP' item using the ◀ or ▶ button.
- 7 Press 'next/select' to enter the 'CALCOMP SETUP' menu.
- 8 Select the 'STEP SIZE' item using the ◀ or ▶ button.
- 9 Press 'next/select' to enter the 'STEP SIZE' menu.
- 10 Select the required value using the ◀ or ▶ button.
- 11 Press 'next/select' to confirm the selected value.
- 12 Press 'Program' to exit the main menu.

Raster formats

CALS

CALS stands for Computer Aided Acquisition and Logistics Support. The Océ 9300 printer supports CALS type 1 files. (Untiled, compatible with CCITT Group 4 format).

NIRS

NIRS is a subset of CALS. The data format consists of a CALS header followed by an NIRS header, followed by TIFF raster data.

TIFF

TIFF stands for Tagged Information File Format.

The Océ 9300 printer supports the following TIFF 6.0 files.

- Uncompressed
- Compressed:
 - PACKBIT byte oriented, runlength
 - Modified Huffman (based on CCITT G3 1D)
 - CCITT Group 3 1 D and 2 D, runlength
 - CCITT Group 4.

C4 (EDMICS)

C4 data format consists of a header followed by compressed CCITT 4 raster data.

Note: *No specific settings are necessary for the above raster languages.*

PostScript level 2

The Océ PostScript level 2 printer option can be used to print PostScript files on the Océ 9400. Océ provides host software which enables you to print from Windows or Macintosh applications.

This option enables your printer to become a true wide-format printer, producing monochrome posters from Illustrator, Word, Excel, QuarkXpress, Powerpoint, Pagemaker, etc., as well as CAD or electronic design applications, among others.

Your PostScript document can be printed on any PostScript printer, in most cases without any decrease in output quality. The Océ 9300 PostScript driver translates the application's internal data into PostScript, and also simplifies the selection of printer features.

PostScript data format selection

When the PostScript option is installed, your printer will automatically recognize the PostScript language data sent to the printer (see 'Defining language settings' on page 48)

Note: *It is very important that every print file terminates with an end-of-print instruction. The PostScript end-of-print instruction is "Ctrl D".*

Any files in the Media Saver will be printed before the PostScript file is interpreted.

If your print is not recognized correctly, resend it with the appropriate data format. Select the data format via the control panel or specify the correct format in a remote control file.

Manual data format selection

The printer must be manually set to PostScript before using interactive mode with the Serial or Ethertalk option (particularly for Macintosh). See 'Setting manual data format' on page 50.

PostScript page layout

The orientation of the printed page on the roll can be either landscape or portrait.

▼ **Selecting the PostScript page layout**

- 1 Press 'Program' to enter the main menu.
- 2 Select the 'CONFIGURATION' item using the ◀ or ▶ button.
- 3 Press 'next/select' to enter the 'CONFIGURATION' menu.
- 4 Select the 'DATA FORMAT' item using the ◀ or ▶ button.
- 5 Press 'next/select' to enter the 'DATA FORMAT' menu.
- 6 Select the 'PS SETUP' item using the ◀ or ▶ button.
- 7 Press 'next/select' to enter the 'PS SETUP' menu.
- 8 Select the 'PAGE LAYOUT' item using the ◀ or ▶ button
- 9 Press 'next/select' to enter 'PAGE LAYOUT' menu.
- 10 Select the required page layout using the ◀ or ▶ button.
- 11 Press 'next/select' to confirm the selected page layout.
- 12 Press 'Program' to exit the main menu.

Default PostScript page size

This option specifies the dimensions of the paper on which your document will be printed. (For example: D, A1, 8.5x11", etc.). This option is useful only when the format is not specified in the PostScript file.

▼ **Selecting the default PostScript page size**

- 1 Press 'Program' to enter the main menu.
- 2 Select the 'CONFIGURATION' item using the ◀ or ▶ button.
- 3 Press 'next/select' to enter the 'CONFIGURATION' menu.
- 4 Select the 'DATA FORMAT' item using the ◀ or ▶ button.
- 5 Press 'next/select' to enter the 'DATA FORMAT' menu.
- 6 Select the 'PS SETUP' item using the ◀ or ▶ button.
- 7 Press 'next/select' to enter the 'PS SETUP' menu.
- 8 Select the 'DEF PAGE SIZE' item using the ◀ or ▶ button.
- 9 Press 'next/select' to enter the 'DEF PAGE SIZE' menu.
- 10 Select the required page size using the ◀ or ▶ button.
- 11 Press 'next/select' to confirm the selected page size.
- 12 Press 'Program' to exit the main menu.

Note: *The page size defined in the PostScript driver overrides the default PostScript page size setting.
Manual feed and Autoscale-to-format are not supported by the PostScript driver. These functions can, however, be activated via the printer operating panel.*

Chapter 6

Advanced menu functions

This chapter describes certain advanced printing functions.



Introduction

The Océ 9300 makes certain advanced printer menu functions available to the user, such as:

- End of Plot time out (see page 73).
- Media saver (see page 74).
- Replot (see page 79).
- Quality Setup (see page 80)
- Transformation (see page 83)
- Password setting for display (see page 87)
- Dump configuration (see page 88).
- Service (see page 89)

End of plot time out

Normally, print files end with an instruction that tells the printer that the file is finished.

However, some print data files do not have an end-of-print instruction. In such cases, the print is considered 'finished' when the printer does not receive any more graphic commands.

The print time-out option sets the delay after which the print is considered finished. You can choose among the following options: 15, 30, 180, or 500 seconds. The default is 180.

▼ **Defining the end of plot time-out**

- 1 Press 'Program' to enter the main menu.
- 2 Select the 'CONFIGURATION' item using the ◀ or ▶ button.
- 3 Press 'next/select' to enter the 'CONFIGURATION' menu.
- 4 Select the 'DATA FORMAT' item using the ◀ or ▶ button
- 5 Press 'next/select' to enter the 'DATA FORMAT' menu.
- 6 Select the 'PLOT TIME OUT' item using the ◀ or ▶ button
- 7 Press 'next/select' to enter the 'PLOT TIME OUT' menu.
- 8 Select the required plot time-out using the ◀ or ▶ button.
- 9 Press 'next/select' to confirm the selected plot time-out.
- 10 Press 'Program' to exit the main menu.

Selecting the media saver

The Océ 9300 offers two options for optimizing usage of print media: Nesting and Autoposition. This applies to both vector and raster formats. The media saver can also be disabled.

The media saver is cleared in the following situations:

- after a time-out
- when selecting another roll or manual feed
- by the flush media saver on the printer operating panel. See also 'Flush media saver' on page 77.

Note: *When automatic roll selection is used, the media saver is inactive.*

The following settings must be specified before the media saver can be used:

- cut methods = synchro
- center = off
- leading and trailing edge = 0.

Nesting

When nesting is selected, prints are stored in queues in the printer's memory, according to their size: 8.5x11" or A, 11x17" or B, 17x22" or C, and mixed 11 x 17"/8.5 x 11". When the queue is full, the drawings are printed across the full width of the media.

The minimum paper length is 16.5 inches. Therefore, when printing 11 x 17" landscape or 8.5 x 11", an extra strip of white paper appears at the end.

If the print is larger than C size, it will not be stored in a queue but will be printed normally. If prints are not standard ISO, ANSI or Architecture sizes, the next larger format is used (see figure 23 on page 75).



Selecting nesting

- 1 Press 'Program' to enter the main menu.
- 2 Select the 'CONFIGURATION' item using the ◀ or ▶ button.
- 3 Press 'next/select' to enter the 'CONFIGURATION' menu.
- 4 Select the 'PLOT MANAGER' item using the ◀ or ▶ button.
- 5 Press 'next/select' to enter the 'PLOT MANAGER' menu.

- 6 Select the 'MEDIA SAVER' item using the ◀ or ▶ button.
- 7 Press 'next/select' to enter the 'MEDIA SAVER' menu.
- 8 Select the 'M/S MODE' item using the ◀ or ▶ button.
- 9 Press 'next/select' to enter the 'M/S MODE' menu.
- 10 Select the 'NESTING' item using the ◀ or ▶ button.
- 11 Press 'next/select' to select the required setting.
- 12 Press 'Program' to exit the main menu.

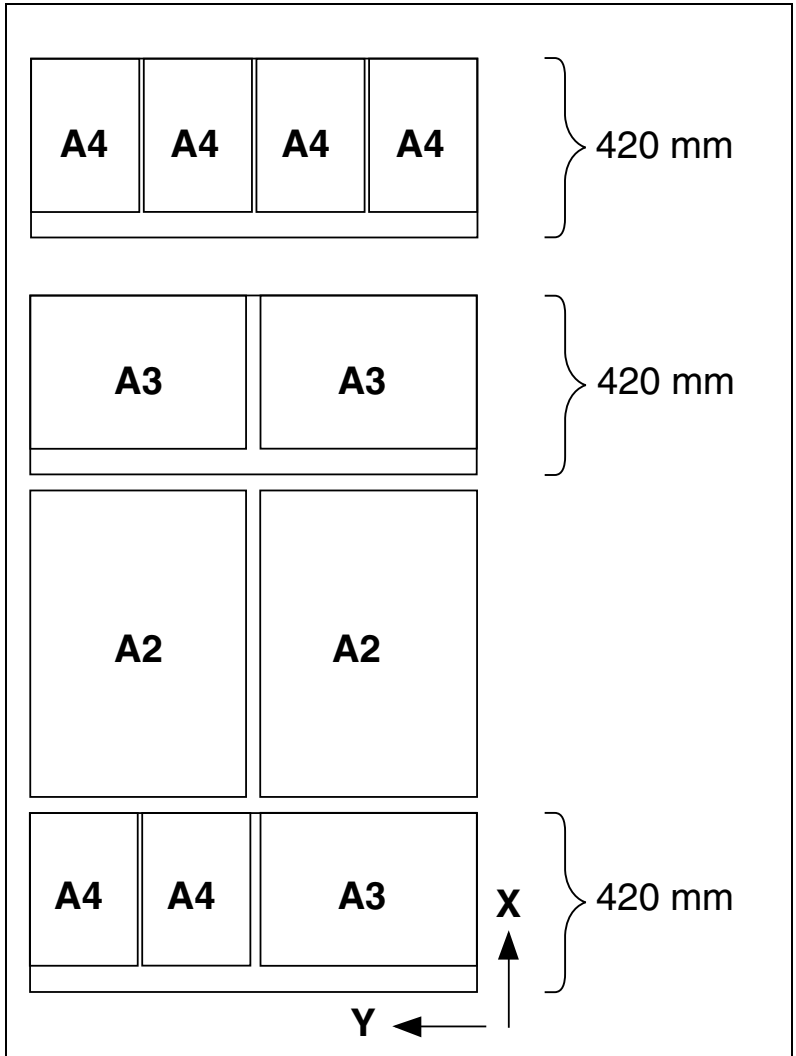

[23] Media saver nesting

Autoposition

This option ignores the origin contained in the print file and automatically shifts the print data to the lower right-hand corner of the media. If necessary, prints are rotated 90 ° to make better use of the available media.

The autoposition feature helps eliminate the need to clip prints and reduces media waste.

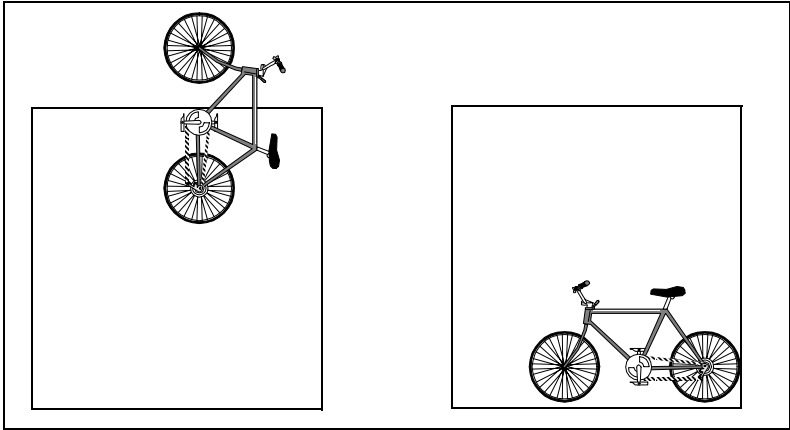

[24] Autoposition to save media

▼ **Selecting autoposition**

- 1 Press 'Program' to enter the main menu.
- 2 Select the 'CONFIGURATION' item using the ◀ or ▶ button.
- 3 Press 'next/select' to enter the 'CONFIGURATION' menu.
- 4 Select the 'PLOT MANAGER' item using the ◀ or ▶ button.
- 5 Press 'next/select' to enter the 'PLOT MANAGER' menu.
- 6 Select the 'MEDIA SAVER' item using the ◀ or ▶ button.
- 7 Press 'next/select' to enter the 'MEDIA SAVER' menu.
- 8 Select the 'M/S MODE' item using the ◀ or ▶ button.
- 9 Press 'next/select' to enter the 'M/S MODE' menu.
- 10 Select the 'AUTO POSITION' item using the ◀ or ▶ button.
- 11 Press 'next/select' to select the required setting.
- 12 Press 'Program' to exit the main menu.

▼ **De-selecting the media saver**

- 1 Use the above procedure and select media saver OFF.

Media saver time-out

As explained in the previous section, when the media saver queue is full, the drawings are printed. However, to prevent unnecessary delays for prints in partially filled queues, a time-out of 1 to 60 minutes can be set, after which the contents of the queue are printed.

▼ **Setting the media saver time-out**

- 1 Press 'Program' to enter the main menu.
- 2 Select the 'CONFIGURATION' item using the ◀ or ▶ button.
- 3 Press 'next/select' to enter the 'CONFIGURATION' menu.
- 4 Select the 'PLOT MANAGER' item using the ◀ or ▶ button.
- 5 Press 'next/select' to enter the 'PLOT MANAGER' menu.
- 6 Select the 'MEDIA SAVER' item using the ◀ or ▶ button.
- 7 Press 'next/select' to enter the 'MEDIA SAVER' menu.
- 8 Select the 'M/S TIME OUT' item using the ◀ or ▶ button.
- 9 Press 'next/select' to enter the 'M/S TIME OUT' menu
- 10 Select the required value using the ◀ or ▶ button.
- 11 Press 'next/select' to confirm the selected value.
- 12 Press 'Program' to exit the main menu.

Flush media saver

This option allows the user to immediately print any print that is held in the media saver memory.

▼ **Setting the flush media saver**

- 1 Press 'Program' to enter the main menu.
- 2 Select the 'FLUSH M.SAVER' item using the ◀ or ▶ button.
- 3 Press 'next/select' to print the file being held.
- 4 Press 'Program' to exit the main menu.

Media saver plot size

When the media saver is set to Nesting, three paper size options are available:
'STD NO CLIP' The print is scaled to fit on the selected paper size. It is not clipped.

'STD CLIPPED' If necessary, the print is clipped to fit onto the selected paper size.

'NON STANDARD' The print is drawn as defined in the print data file. Paper size depends on the size of the plot.

The default is **'NON STANDARD'**.

▼ **Setting the media saver plot size**

- 1 Press 'Program' to enter the main menu.
- 2 Select the 'CONFIGURATION' item using the ◀ or ▶ button.
- 3 Press 'next/select' to enter the 'CONFIGURATION' menu.
- 4 Select the 'PLOT MANAGER' item using the ◀ or ▶ button.
- 5 Press 'next/select' to enter the 'PLOT MANAGER' menu.
- 6 Select the 'MEDIA SAVER' item using the ◀ or ▶ button.
- 7 Press 'next/select' to enter the 'MEDIA SAVER' menu.
- 8 Select the 'M/S PLOT SIZE' item using the ◀ or ▶ button.
- 9 Press 'next/select' to enter the 'M/S PLOT SIZE' menu
- 10 Select the required setting using the ◀ or ▶ button.
- 11 Press 'next/select' to confirm the selected setting.
- 12 Press 'Program' to exit the main menu.

Replot

Normally, files are discarded after being processed and printed. The replot function overrides this feature, preventing the file from being discarded. To make extra copies/prints from the operating panel, you must select 'REPLOTTING ENABLE'.

The default is 'off'.

▼ Enabling replot

- 1 Press 'Program' to enter the main menu.
- 2 Select the 'CONFIGURATION' item using the ◀ or ▶ button.
- 3 Press 'next/select' to enter the 'CONFIGURATION' menu.
- 4 Select the 'REPLOTTING' item using the ◀ or ▶ button.
- 5 Press 'next/select' to enter the 'REPLOTTING' menu.
- 6 Select the required setting using the ◀ or ▶ button.
- 7 Press 'next/select' to confirm the setting.
- 8 Press 'Program' to exit the main menu.

Setting the number of copies

This option enables you to print multiple prints of the file currently stored in the printer's memory. The default is 0, and a maximum of 99 prints can be made using this option.

Note: *This option is active only when replotting is enabled.*

▼ Defining the number of prints

- 1 Press 'Program' to enter the main menu.
- 2 Select the '# COPIES' item using the ◀ or ▶ button.
- 3 Press 'next/select' to enter the '# COPIES' menu.
- 4 Select the required number of copies using the ◀ or ▶ button.
- 5 Press 'next/select' to confirm the number of copies.
- 6 Press 'Program' to exit the main menu.

Quality setup

Quality setup includes:

- Poster mode, to print documents with large black areas.
- Rendering, to change the first 16 pen patterns into another 16 gray-shaded pen patterns.
- Image type, to use the correct scaling method.

Poster mode

Poster mode is useful when you must make prints which contain large black areas.

▼ **Enabling Poster mode**

- 1 Press 'Program' to enter the main menu.
- 2 Select the 'QUALITY' item using the ◀ or ▶ button.
- 3 Press 'next/select' to enter the 'QUALITY' menu.
- 4 Select the 'POSTER MODE' item using the ◀ or ▶ button.
- 5 Press 'next/select' to enter the 'POSTER MODE' menu.
- 6 Select the Poster mode on/off using the ◀ or ▶ button.
- 7 Press 'next/select' to confirm the Poster mode.
- 8 Press 'Program' to leave the main menu.

Note: *This setting can be overridden by Plot Director, the drivers, or the setting on the scanner operating panel.*

Rendering

The rendering function can be divided into clustered or cloud. With this option you can change the first 16 pen patterns into another 16 gray-shaded pen patterns.

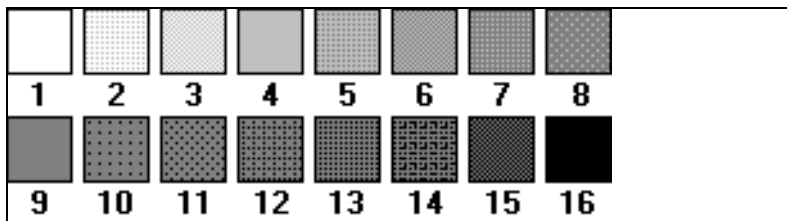

[25] The rendering function gray-shaded patterns

Attention: *Clustered must be used if your originals contain large gray areas. Use cloud to get an optimal result with line drawings.*

▼ **Defining rendering**

- 1 Press 'Program' to enter the main menu.
- 2 Select the 'QUALITY' item using the ◀ or ▶ button.
- 3 Press 'next/select' to enter the 'QUALITY' menu.
- 4 Select the 'RENDERING' option using the ◀ or ▶ button.
- 5 Press 'next/select' to enter the 'RENDERING MENU'.
- 6 Select the required option, clustered or cloud, using the ◀ or ▶ button.
- 7 Press 'next/select' to confirm the selected option.
- 8 Press 'Program' to leave the main menu.

Image type

The Océ 9300 has an optimized quality mode for scaling down raster files in order to deliver the best possible quality. The default setting is **PHOTO**.

CAD will use scaling in order not to lose thin lines when scaling down raster files or converting the resolution of the file to the resolution of the rpinter(300 dpi).

PHOTO will use pixel scaling.



Defining image type

- 1 Press 'Program' to enter the main menu.
- 2 Select the 'QUALITY' item using the ◀ or ▶ button.
- 3 Press 'next/select' to enter the 'QUALITY' menu.
- 4 Select the 'IMAGE TYPE' option using the ◀ or ▶ button.
- 5 Press 'next/select' to enter the 'IMAGE TYPE MENU'.
- 6 Select the required option **CAD** or **PHOTO** using the ◀ or ▶ button.
- 7 Press 'next/select' to confirm the selected option.
- 8 Press 'Program' to leave the main menu.

Transformation

The Océ 9300 allows the user to change the position of the image on the print in the following ways: Image rotation and scaling functions. This applies only to **vector** languages and is possible only when the media saver is switched off.

Print rotation

This function allows you to set the degree of rotation applied to a print. Four rotation values are possible: 0°, 90°, 180°, and 270°. The default is 0°. This function applies only to vector languages.

▼ Defining the print rotation

- 1 Press 'Program' to enter the main menu.
- 2 Select the 'CONFIGURATION' item using the ◀ or ▶ button.
- 3 Press 'next/select' to enter the 'CONFIGURATION' menu.
- 4 Select the 'PLOT MANAGER' item using the ◀ or ▶ button.
- 5 Press 'next/select' to enter the 'PLOT MANAGER' menu.
- 6 Select the 'TRANSFORM' item using the ◀ or ▶ button.
- 7 Press 'next/select' to enter the 'TRANSFORM' menu.
- 8 Select the 'ROTATION' item using the ◀ or ▶ button.
- 9 Press 'next/select' to enter the 'ROTATION' menu.
- 10 Select the required value using the ◀ or ▶ button.
- 11 Press 'next/select' to confirm the setting.
- 12 Press 'Program' to exit the main menu.

Print scaling

The X-scale and Y-scale can be individually set to values ranging from 0.05 to 20.0. The default is 1.0. This function applies only to vector languages.

▼ Defining print scaling

- 1 Press 'Program' to enter the main menu.
- 2 Select the 'CONFIGURATION' item using the ◀ or ▶ button.
- 3 Press 'next/select' to enter the 'CONFIGURATION' menu.
- 4 Select the 'PLOT MANAGER' item using the ◀ or ▶ button.
- 5 Press 'next/select' to enter the 'PLOT MANAGER' menu.

- 6 Select the 'TRANSFORM' item using the ◀ or ▶ button.
- 7 Press 'next/select' to enter the 'TRANSFORM' menu.
- 8 Select the 'SCALING' item using the ◀ or ▶ button.
- 9 Press 'next/select' to enter the 'SCALING' menu.
- 10 Select the required scaling method using the ◀ or ▶ button.
- 11 Press 'next/select' to enter the appropriate menu.

Follow the procedure below to define scaling for the X and Y axis individually:

- 12 Select the required setting using the ◀ or ▶ button.
- 13 Press 'next/select' to confirm the setting.
- 14 Press 'Program' to exit the main menu.

Note: *When autoscale is selected, x-scaling and y-scaling are not applicable.*

Autoscaling

The purpose of Autoscale is to apply exact ISO/ANSI/Architect formats to documents. The same scaling factor is applied to the X and Y axis. An auto rotation can be performed to attain the best auto scale factor.

Although the Media Saver and the Autoscaling Mode are controlled separately, they do interact.

Autoscale mode can be activated in two ways:

- Autoscale to a predefined format (ISO/ANSI/Architect)
- best fit

The user can combine Autoscale and Autoposition: plots are first autoscaled (best fit or scale to format, if required), and then autopositioned (if required).

Fit-to-Format Mode:

All the drawings regardless their sizes, are reduced/enlarged to one specific standard size. This option can be combined with the Media Saver option.

The list of predefined formats depends on the media format selected via the printer operating panel.

Users can enlarge drawings to poster size in order to make presentations to large audience. They can also reduce documents to easily mail them or archive them in standard A3 (11x17") or A4 (8.25x11") books.

Best fit Mode:

In this mode, the drawing will be reduced to match either the length or the width of the format loaded in the machine, with no loss of information (no clipping). Only plots larger than the loaded media size are scaled or rotated; all others are printed without scaling.

Note: *This mode does not enlarge drawings, it only reduces them.*

This option cannot be used with the Nesting option. If Nesting is enabled, this option will have no effect.

This mode prevents clipping of plots that are larger than the media loaded in the machine.

If 'AUTOSCALE' is off and if your drawing is larger than the physical dimensions of the media, the printer will automatically clip the area outside the margins. The 'CLIPPING' message appears on the display, and the printer automatically compensates for the discrepancy. Clipping does not affect the position of the print origin.

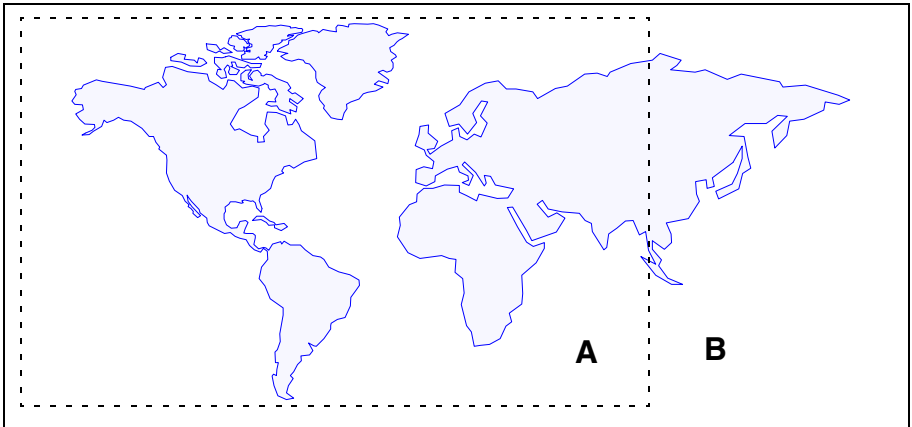

[26] Print clipping

A: Only the left part of the drawing is plotted.

B: The part of the drawing outside the margins is clipped.



Defining autoscaling

- 1 Press 'Program' to enter the main menu.
- 2 Select the 'CONFIGURATION' item using the ◀ or ▶ button.
- 3 Press 'next/select' to enter the 'CONFIGURATION' menu.
- 4 Select the 'PLOT MANAGER' item using the ◀ or ▶ button.
- 5 Press 'next/select' to enter the 'PLOT MANAGER' menu.
- 6 Select the 'TRANSFORM' item using the ◀ or ▶ button.
- 7 Press 'next/select' to enter the 'TRANSFORM' menu.
- 8 Select the 'SCALING' item using the ◀ or ▶ button.
- 9 Press 'next/select' to enter the 'SCALING' menu.
- 10 Select 'AUTOSCALE' on using the ◀ or ▶ button.
- 11 Press 'next/select' to enter the 'AUTOSCALE' menu.
- 12 Select 'OFF, BEST FIT, A4, A3, A2, A1' or 'A0' using the ◀ or ▶ button.
- 13 Press 'next/select' to confirm the required setting
- 14 Press 'Program' to exit the main menu.

Password

Because the printer may be operated in your work environment by users with differing skill levels, three menu access levels can be set for security reasons. The display menu allows fully authorized users to access these different printer menu levels, from the locked level to the full menu levels, by means of passwords.

The short menu level allows access to the display, cancel plot, media settings and plot menus, enabling users to set plot parameters, execute the printer test and demo plot, set the number of copies and cancel plots in progress. The password for the short menu is: ◀ ◀ 'previous' ▶ ▶.

The full menu level allows access to the display, plot, configuration, cancel plot and number of copies menus, as well as their sub-menus. The password for the full menu is: ◀ ▶ 'previous' ▶ ◀.

The locked level locks the entire printer. When this level is set, the printer acts only as an output device, receiving commands from your workstation via remote control. Although commands cannot be entered on the operating panel, informative messages are still displayed. The password for the locked menu is: 'previous' ◀ ▶ 'previous' ◀.

▼ **Setting the menu access level**

- 1 Press 'Program' to enter the main menu.
- 2 Select the 'DISPLAY' item using the ◀ or ▶ button.
- 3 Press 'next/select' to enter the 'DISPLAY' menu.
- 4 Select the required menu level using the ◀ or ▶ button.
- 5 Press 'next/select' to confirm.
- 6 Depending on the selected menu level, a password must be entered.
- 7 Press 'next/select' to confirm the password.
- 8 Press 'Program' to exit the main menu.

Dump configuration

Dumping the configuration is an easy way to obtain a list of the current print settings on paper.

Note: *Note: The dump configuration cannot be performed while a file is being processed.*

▼ Dumping the configuration

- 1 Press 'Program' to enter the main menu.
- 2 Select the 'CONFIGURATION' item using the ◀ or ▶ button.
- 3 Press 'next/select' to enter the 'CONFIGURATION' menu.
- 4 Select the 'UTILITIES' item using the ◀ or ▶ button.
- 5 Press 'next/select' to enter the 'UTILITIES' menu.
- 6 Select the 'DUMP CONFIG' item using the ◀ or ▶ button.
- 7 Press 'next/select' to confirm 'DUMP CONFIG'.
- 8 Press 'Program' to leave the main menu.

Service

This menu is only meant for the Océ service technician.

Chapter 7

Solving problems

This chapter describes problems that may occur while using the Océ 9300.



Solving problems

This chapter documents problems that may occur with the Océ 9300, and describes how to solve them.

There are three types of printer warnings/errors:

- Warnings
- Operator-recoverable errors (printer)
- Machine-recoverable errors

Printer warnings

Warnings appear in the display. The printer will continue to print, but print quality may diminish.

Warnings

CONDITIONING

SHEET TOO SHORT

SHEET NOT FED

Description

The printer is measuring toner

The sheet fed into the manual feed is shorter than the print

Within the specified time-out, no sheet has been fed into the manual feed, and so the plot is canceled

Operator recoverable errors

The printer stops immediately when it detects an operator-recoverable error. An error message displays on the panel. The user must take action to solve the problem.

Message	Description
<i>ERROR FEED TABLE</i>	Print media in feed table or feed table not closed Remove the paper and/or close the feed table
<i>PAPER REMOVED</i>	The paper has been removed from the feed table during a print
<i>PAPER TOO SHORT</i>	The print material is too short Remove the print media
<i>PAPER JAM</i>	Print media has jammed in the machine Remove the jammed media
<i>FEED TABLE OPEN</i>	The feed table is not closed properly Close the feed table
<i>CUTTER ERROR</i>	The print media is not properly cut Remove the print media
<i>ROLL EMPTY</i>	The selected roll is empty Remove the empty roll and place a new roll of print media into the roll unit
<i>PAPER JAM ROLL</i>	Print media has jammed in the roll unit Remove the print media
<i>ROLLUNIT OPEN</i>	The roll unit is open Close the roll unit
<i>REFILL TONER</i>	Add toner
<i>OPEN ROLLUNIT</i>	Open the roll unit to remove the print media
<i>CHECK OUTPUT-TRAY</i>	Print media has jammed in the active output tray Remove the jammed print media and press Continue

Clearing paper jams

When a jam occurs, a message appears on the operating panel. If paper misfeeds occur frequently, make sure that:

- The roll(s) are loaded correctly and the media is fed as indicated.
- The correct media is used (see 'Print media that can be used' on page 103).
- No scraps of material are blocking the paper path.

▼ Clearing paper jams in the media feed section

- 1 Turn the printer off.
- 2 Open the cover of the roll unit.
- 3 Lower the feed table, using the two catches on the front of the printer underneath the feed table (see figure 27).

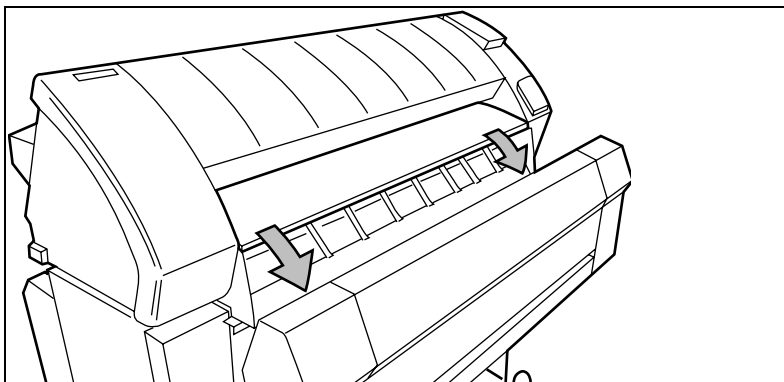

[27] Lowering the feed table

- 4 Remove the jammed material.
Note: *Check thoroughly to make sure that no scraps of material remain.*
- 5 Close the feed table.
- 6 Close the cover of the roll unit.
- 7 Turn the printer on.

If the paper jam cannot be cleared by opening the feed table, then open the fuser section.



Clearing paper jams in the fuser section

- 1 Turn the printer off.
- 2 Unscrew the access nut on the left-hand side of the machine and open the cover (see figure 28).

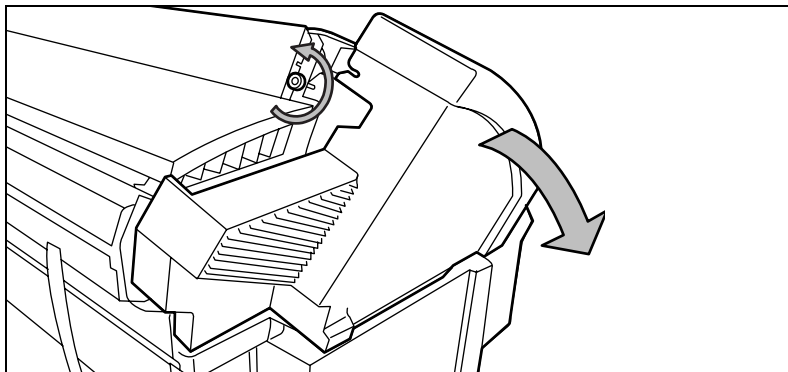

[28] Unscrewing the access nut and opening the cover

- 3 Lift the green handle (see figure 29).

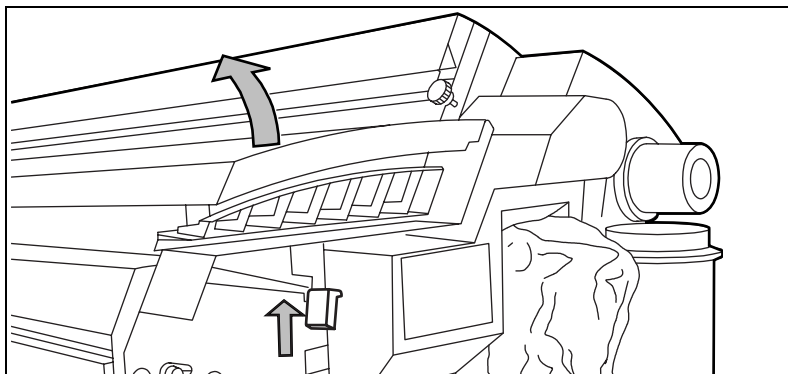

[29] Lifting the green handle

- 4 Open the fuser unit (see figure 30).

Caution: *If the printer has been used recently, the fuser may be hot.*

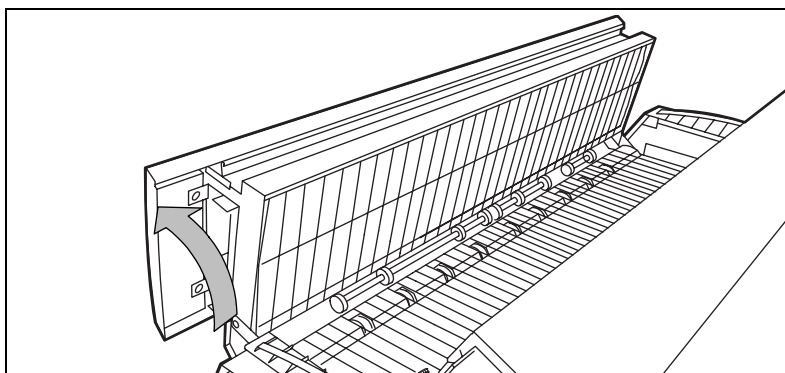

[30] Opening the fuser unit

- 5 Remove the jammed material.

Attention: *Be careful! The toner is not fused.*

- 6 Lift the green handle and close the fuser unit.
- 7 Close the left cover and tighten the access nut.
- 8 Turn the printer on.

Machine-recoverable errors

Machine recoverable errors are indicated by the appearance of a 4-digit error code in the display.

▼ Solving a machine error

- 1 Turn off the printer and check the entire paper path. See 'Clearing paper jams' on page 94.
- 2 Then turn the printer on again.
If no error number appears in the display, you can continue printing.

If the machine error remains, call the key operator.

Appendix A

Overview and tables



Product specifications

The Océ 9300 is a wide-format, low- to mid-volume copying and printing system.

Printer

<i>Technology</i>	electrophotography (LED head)
<i>Photoconductive drum</i>	organic photoconductor (OPC)
<i>Printing speed</i>	3 m/min (10 feet/min)
<i>Warm-up time</i>	none, once it is turned on
<i>Media feed</i>	manual and single- or double-roll automatic
<i>Toner system</i>	closed
<i>Maximum printable area</i>	the maximum printable area depends on size of installed memory and file complexity, but can be up to 15 m (49 feet)
<i>Poster mode</i>	increases the density of the copy

Controller

<i>Standard memory</i>	32 MB
<i>Vector data formats</i>	HP-GL, HP-GL/2, CalComp 906/907, VDF, BGL, Edmics
<i>Raster data formats</i>	HP-RTL, Cals type 1, TIFF 6.0 G3 & G4, NIRS, C4-G4
<i>Language sensing</i>	automatic and via display panel
<i>Multicopy</i>	up to 99
<i>Interfacing</i>	automatic switching: RS-232 serial Centronics parallel Ethernet (optional)

■ Options

- Automatic 2-roll unit
- Memory upgrade to 48 or 64 Mb
- PostScript level 2
- Ethernet interface
- High capacity delivery tray

Interfaces

Centronics protocol

Centronics uses hardware handshaking. The computer sends a STROBE signal to move each byte of data into the printer, at which time the printer signals BUSY. When the transfer is complete, the printer sends ACKNOWLEDGE to the computer and another cycle can begin.

Serial protocols

Two types of computer-to-printer handshaking, (and their variants), are available on the Océ 9300 printer:

- Hardware
- XON/XOFF

Depending on the emulation selected, handshake protocols can be set either through the software or the control panel.

When invoking a handshake protocol manually, the printer offers you the following character transmission handshaking selection:

- CTS2 for hardware handshaking
- XON4 for XON/OFF software handshaking

Your host or software documentation should tell you which handshaking is needed.

- XON4: The printer sends XON when its buffer has enough memory to receive character data. It sends an XOFF character to the computer when its buffer is almost full, indicating that the computer should stop sending characters.
- CTS2: Whenever the printer's buffer has enough memory to accept characters, it activates the CTS signal. It then de-activates the signal when the buffer is full.

Note: *Hardware handshaking is enabled using the HP-GL ESC.P3 instruction. Xon/Xoff handshaking is enabled via the software, using the ESC.P1 HP-GL instruction.*

Ethernet protocol

If the printer is equipped with an Ethernet interface, it can be connected to:

- TCP/IP
- IPX (Novell Netware)
- Ethertalk network.
- NETBIOS (over TCP/IP).

For additional details, refer to the Ethernet print server user manual.

Centronics port configuration

The Centronics parallel port is located at the rear of the printer. It is an Amphenol 36-pin female mini- connector.

The following table describes the Centronics port pin assignments. For further details, refer to the IEEE P1284 standard.

Printer Pin No.	Signal direction	Name of the signal
1	Printer to host	BSYBusy
2	Printer to host	SELECTSelect
3	Printer to host	ACKNAcknowledge
4	Printer to host	FAULTNFault
5	Printer to host	PAPEROUTPaper error
6	Host to printer	Data 1 Data 1 (LSB)
7	Host to printer	Data 2Data 2
8	Host to printer	Data 3Data 3
9	Host to printer	Data 4Data 4
10	Host to printer	Data 5Data 5
11	Host to printer	Data 6Data 6
12	Host to printer	Data 7Data 7
13	Host to printer	Data 8Data 8 (MSB)
14	Host to printer	INITNInitialize
15	Host to printer	STROBENStrobe
16	Host to printer	SELECTINNSelect in
17	Host to printer	AUTOFDN
18	Host to printer	Host Logic High
19-35	-----	GNDGround
36	Printer to host	Peripheral Logic High

STROBE is the dialog signal.

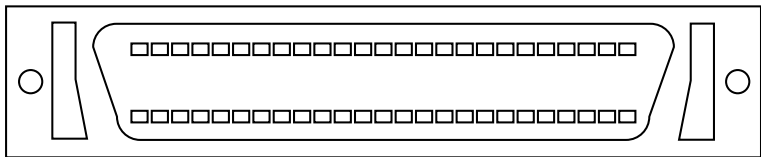

[31] Centronics connector

Serial port configuration

The RS-232/423-C serial port is located at the rear of the printer. It is a DIN 8-pin female mini-connector (for printer in DCE - Data Communications Equipment). It does, however, accept DTE (Data Terminal Equipment) signals when DTE is selected under the PORT sub-menu of the Connections Menu.

The RS-423-C norm is an improved version of the RS-232-C serial connection.

The following table describes the serial port pin assignment.

Printer Pin No.	Signal direction	Name of the signal
1	Host to printer	DTRData terminal ready
2	Printer to host	CTS Clear to send
3	Host to printer	TX Transmit data
4	-----	GNDProtective ground
5	Printer to host	RXReceived print data
6	Host to printer	RTSReady to send
8	Printer to host	DSRData set ready

DTR is the dialog signal.

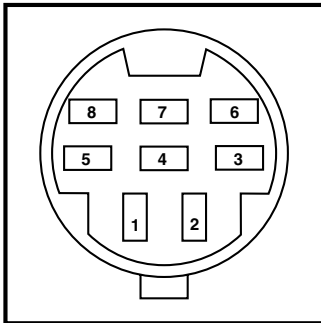

[32] Serial connector

Print media that can be used

Océ machines and media are designed to complement each other for optimal quality and performance. We therefore recommend using only approved Océ media in the

Océ 9300.

A full list of Océ materials suitable for use in the Océ 9300, including plain paper, transparencies, colored paper and various polyester films is available from your Océ representative.

The maximum length of the print material is 175 m (492 feet) when 20 lb. bond material is used, and 460 feet in the case of 27 lb. paper. The diameter of the roll holder is 3 inches.

ISO	ANSI	ARCH
<i>A0 (841x1189 mm)</i>	<i>34"(34x44")</i>	<i>36"(36x48")</i>
<i>A1(594x841 mm)</i>	<i>22"(22x34")</i>	<i>24"(24x36")</i>
<i>A2(420x594 mm)</i>	<i>17"(17x22")</i>	<i>18"(18x24")</i>
<i>A3(297x420 mm)</i>	<i>11"(11x17")</i>	<i>12"(12x18")</i>
<i>34"(34x44")</i>	<i>36"(36x48")</i>	<i>34"(34x44")</i>
<i>22"(22x34")</i>	<i>24"(24x36")</i>	<i>22"(22x34")</i>
<i>17"(17x22")</i>	<i>18"(18x24")</i>	<i>17"(17x22")</i>
<i>11"(11x17")</i>	<i>12"(12x18")</i>	<i>11"(11x17")</i>
<i>36"(36x48")</i>	<i>30"(30x42")</i>	<i>30"(30x42")</i>
<i>24"(24x36")</i>	<i>A0 (841x1189 mm)</i>	<i>A0 (841x1189 mm)</i>
<i>18"(18x24")</i>	<i>A1(594x841 mm)</i>	<i>A1(594x841 mm)</i>
<i>12"(12x18")</i>	<i>A2(420x594 mm)</i>	<i>A2(420x594 mm)</i>
<i>30"(30x42")</i>	<i>A3(297x420 mm)</i>	<i>A3(297x420 mm)</i>
<i>500 mm(500x707 mm)</i>	<i>500 mm(500x707 mm)</i>	<i>500 mm(500x707 mm)</i>
<i>700 mm(700x1000 mm)</i>	<i>700 mm(700x1000 mm)</i>	<i>700 mm(700x1000 mm)</i>
<i>B1(707x1000 mm)</i>	<i>B1(707x1000 mm)</i>	<i>B1(707x1000 mm)</i>

Overview of copy material

<i>Print material</i>	<i>Recommended</i>	
Plain paper	20 lb. bond	
Transparent paper	27 lb.	
Vellum	20 lb.	
Polyester film	3.5 mil	
ECO papers	20 lb. bond	
	<i>Minimum</i>	<i>Maximum</i>
Width	279 mm (11")	914 mm (36")
Length	420 mm (16.5") (A3)	Guaranteed print quality up to ca. 3 meters or 10 feet. This is also the limit for prints and multiple copies made on the Océ 9300. For single copies/prints made on the Océ 9300 printer or hybrid, the maximum length may be up to 15 meters (about 50 feet), but the operator must take into account that the copy/print quality may not conform to all quality requirements.

Attention: *Paper and transparent media are sensitive to high humidity. To ensure optimal copy quality, keep all copy media in its original packaging, especially at night.*

Attention: *Curled sheets of print media must be fed in with the curl facing down to avoid damaging the drum.*

Appendix B

Hardware components and operating panel



Océ 9300

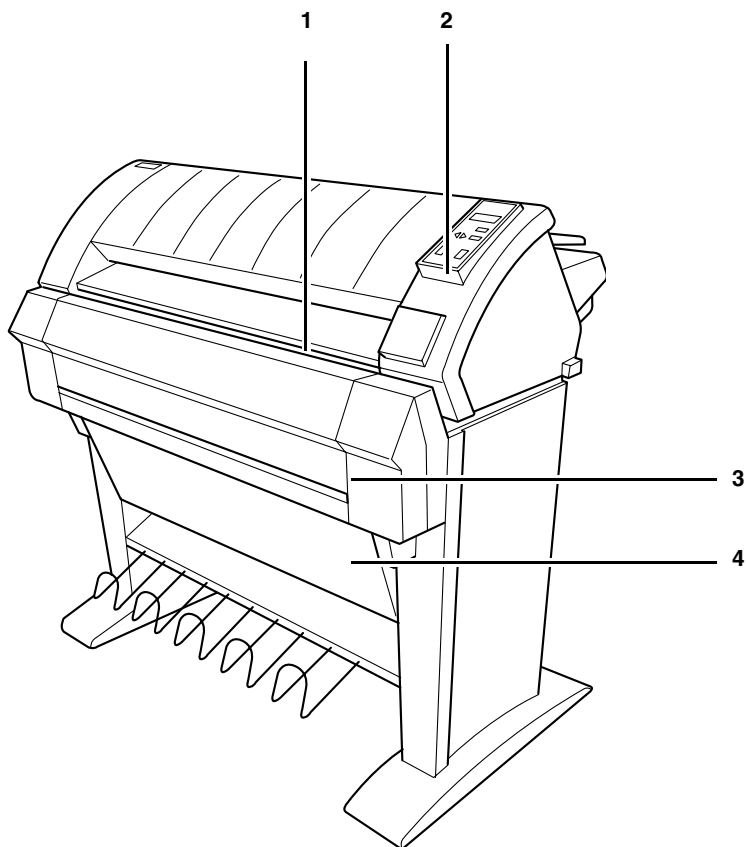

- 1 Feed table printer
- 2 Operating panel printer
- 3 Paper roll 1
- 4 Paper roll 2

Operating panel

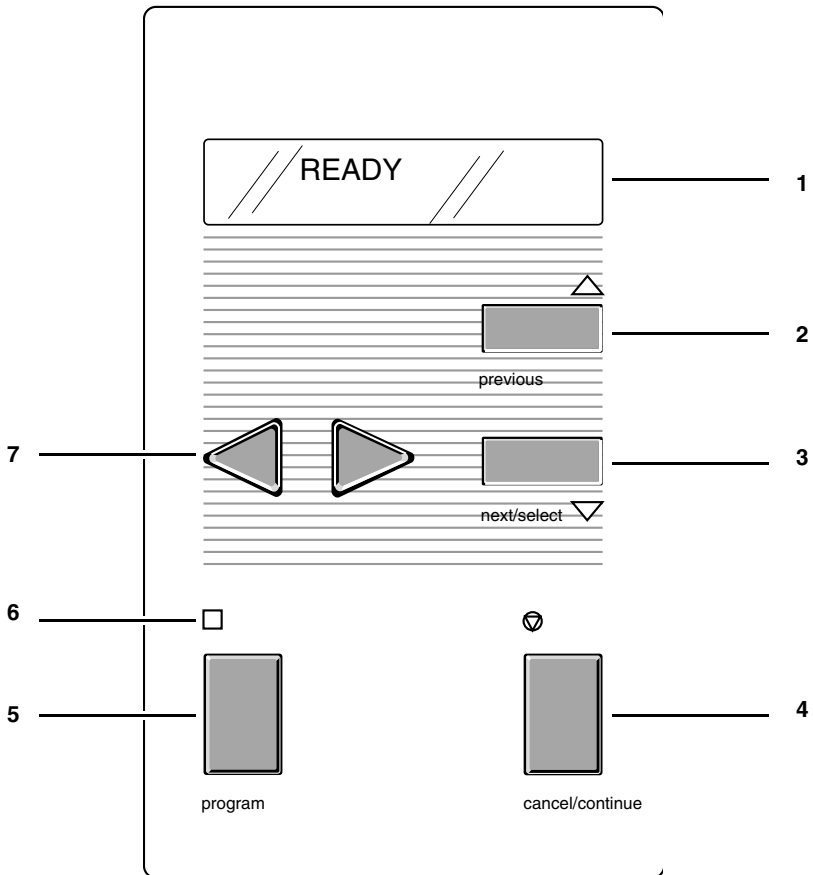

- 1 Display
- 2 Previous button
- 3 Next/select button
- 4 Cancel/continue button
- 5 Program button
- 6 Indicator
- 7 Browse buttons

Appendix C

Safety information



Instructions for safe use

Océ machines and materials have been developed and tested in accordance with the strictest international safety standards. To ensure your safety while working with these products, it is important that you observe the following safety rules:

- Do not remove any screws from fixed panels.
- The machine is not user-serviceable except for the components and maintenance materials mentioned in this manual.
- Do not place any liquids on the machine.
- Use maintenance materials or other materials for their intended purpose only. Keep maintenance materials out of the reach of children.
- Do not mix cleaning fluids or other materials.
- To avoid risks, all modifications to Océ equipment must be performed only by Océ service personnel. We recommend that you use attachment cables specified by Océ.
- The printer has been fitted with an ozone filter.
- Do not bridge any mechanical or electrical circuit breakers.
- Do not use an extension cord to connect the machine.
- Locate the machine close to an electrical outlet that is easily accessible.
- The switch in the fixed connection (if any) should be easily accessible.
- This machine has not been designed for connection to an IT power system. (An IT power system is a voltage network in which the neutral wire is grounded).
- Do not block the ventilation openings of the machine.
- Make sure that the machine is placed on a level, horizontal surface, stable and strong enough to support the weight of the machine. See the Océ 9300 safety data sheet in this appendix for information about the weight of the machine.
- Make sure that there is sufficient space around the machine. This facilitates reloading materials as well as maintenance.
- Do not place the machine in rooms which are subject to excessive vibration.
- Do not place the machine in rooms which are too small or insufficiently ventilated. See the Océ 9300 safety data sheet in this appendix for information about space and ventilation requirements.
- Always use materials recommended by Océ and developed for this Océ machine. Materials not approved by Océ may result in machine failures.
- Do not use the machine if it makes unusual sounds. Remove the plug from the electrical outlet and contact Océ Customer Service.

Safety data sheets

Disclaimer The disclaimer below is valid for all safety data sheets in this manual.

These safety data sheets have been compiled to the best of our knowledge as a compact guide to safe handling of this product. We reserve the right to revise safety data sheets as new information becomes available. It is the user's responsibility to determine the suitability of this information for the adoption of safety precautions as may be necessary, and to contact the company to make sure that the sheet is the latest one issued. If and in so far as limitation of liability is permitted under the applicable laws, we do not accept liability for any inaccuracy that may occur in this information.

Safety data sheet Océ 9300 printer

PRODUCT SAFETY DATA SHEET



Number E-708-a-US
Date August 1999

Model	Océ 9300		
Description	Electrostatic printer, instant printing, console model, plain paper, organic photoconductive drum, powder toner		
Max. process speed	3 m/min		
Dimensions	Width	Depth	Height
Weight	1 roll	2 roll	
	1352 mm	1352 mm	
	918 mm	918 mm	
	1251 mm	1251 mm	
	149 kg	159 kg	
Voltage	115 V		
Frequency	60 Hz		
Current-rated	15 A		
Current-max	20 A		
Power consumption	1500 W at continuous operation		
Power consumption, stand by	46 W		
Mains connection	Cable with plug		
Safety class	I (IEC 536) Protective earth connection		
Protection class	IP 20 (IEC 529)		
Sound pressure level (at bystander position)	Stand by	In operation	
Sound power level	0 dB(A)	main body 51 dB(A) impulse $\Delta L_1 = 2$ dB(A)	
Radio interference	0 dB(A)	main body 61 dB(A)	
Radiation	Complies with FCC rules and regulations, part 15 class A		
Heat emission	Below the Threshold Limit Values for UV, Visible and IR radiation (TLV list of ACGIH)		
Ozone emission	Standby 46 W; at continuous operation 1500 W 0,02 mg/min at continuous operation		
Room volume	Recommendation: min. 25 m ³		
Room ventilation	Recommendation: min. 12,5 m ³ /h (natural ventilation)		
Use simulation at random operation	With a room volume and ventilation as recommended and a daily volume of 100 m (much more than average) the use simulation at random operation gives the following ozone concentrations:		
	- Time weighted average	0,002 mg/m ³	(0,001 ppm)
	- Peak	0,008 mg/m ³	(0,004 ppm)
	<i>Threshold Limit Value/Occupational Exposure Limit (Time Weighted Average) for ozone</i>	0,2 mg/m ³	(0,1 ppm)
	<i>Odour Perception Limit for ozone</i>	0,04 mg/m ³	(0,02 ppm)
Consumables	Océ OPC Drum (Océ Safety Data Sheet E-218) Océ B4 Toner (Océ Safety Data Sheet E-196) Océ D4 Developer (Océ Safety Data Sheet E-197) Océ Copying Materials. This apparatus is suitable for processing recycling paper. Ask Océ for suitable recycling paper.		
Additional safety information	The ozone filter does not have to be replaced to keep the ozone concentration in the workplace below 0,04 mg/m ³ (i.e. the life of the filter equals that of the apparatus).		
Listed according to standard UL 1950 and CAN/CSA-C22.2 No.950			
			
<small>LISTED 927F INFORMATION TECHNOLOGY EQUIPMENT E 69871</small>			

Copyright © 1999 Océ-Technologies B.V., Venlo, NL

The contents of this safety data sheet is subject to the disclaimer on page 111 of this manual.

Appendix D

Miscellaneous



How to read this manual

The consistent style that is used in this manual enables you to quickly become familiar with the use of this manual and ultimately the Océ 9300.

Description Each section or subsection contains a description of the feature or operation identified in the title. It might also include possible applications, as well as any guidelines that you should bear in mind.

Procedures A description is followed by a procedure. A procedure always begins with a phrase which briefly describes the procedure, followed by a series of numbered steps that take you, step by step, through all phases of performing the operation.

Figures and tables Figures and tables are titled and numbered sequentially throughout this manual. Figures include pictures of product components, screen dumps, examples, and diagrams of concepts discussed in the description.

Attention getters There are several types of information to which we draw your attention. This information is classified as follows:

Note: *In a 'Note', information is given about matters which ensure the proper functioning of the machine or application, but useful advice concerning its operation may also be given.*

Attention: *The information that follows 'Attention' is given to avoid damage to your copy or original, the copier or printer, data files, etc.*

Caution: *The information that follows 'Caution' is given to prevent you suffering personal injury. .*

User survey

Did you find this manual to be accurate?

- Yes
- No

Were you able to operate the product after reading this manual?

- Yes
- No

Does this manual provide adequate background information?

- Yes
- No

Is the format of this manual convenient in size, easy to read and layed out well?

- Yes
- No

Did you find the information you were looking for?

- Always
- Most of the times
- Sometimes
- Not at all

How did you find the information you were looking for?

- Table of contents
- Index
- Neither

Are you satisfied with this manual?

- Yes
- No

Thank you for evaluating this manual.

If you have any other comments or concerns, please explain them on the following page.

Comments:

Date:

This reader's comment sheet is completed by:

Name (optional):

Occupation:

Company:

Phone:

Address:

City:

Country:

Please return this sheet to:

Océ-Technologies B.V.
Attn: ITC-User Documentation
P.O. Box 101
5900 MA Venlo
The Netherlands

Send you comments by E-mail to: itc-userdoc@oce.nl

For the addresses of local Océ organizations see: www.oce.com

Addresses of local Océ organizations

Océ-Australia Ltd.
P.O.Box 363
Ferntree Gully MDC VIC 3165
Australia

Océ-Österreich GmbH
Postfach 95
1233 Vienna
Austria

Océ-Belgium N.V./S.A.
Avenue J.Bordetlaan 32
1140 Brussels
Belgium

Océ-Brasil Comércio e Industria Ltda.
Caixa Postal 3187
01060-970 Sao Paulo, SP
Brazil

Océ-Canada Inc.
525, Logan Avenue,
Toronto, Ontario M4K 3B3
Canada

Océ Office Equipment (Beijing) Co Ltd.
Xu Mu Cheng
Chaoyang District
Beijing 100028
China

Océ-Česká republika s.r.o.
Hanusova 18
14021 Praha 4
Pankrác,
Czech Republic

Océ-Danmark A.S.
Kornmarksvej 6
DK 2605 Brøndby
Denmark

Océ-France S.A.
32, Avenue du Pavé Neuf,
93161 Noisy-le-grand, Cedex
France

Océ-Deutschland GmbH
Postfach 101454
4330 Mülheim an der Ruhr (13)
Deutschland

Océ (Hong Kong China) Ltd.
12/F 1202 The Lee Gardens
33 Hysan Avenue, Causeway Bay
Hong Kong

Océ-Hungária Kft.
P.O.B. 237
1241 Budapest
Hungary

Océ-Italia S.p.A.
Strada Padana Superiore 2/B
20063 Cernusco sul Naviglio (MI)
Italia

Océ Systems (Malaysia Sdn. Bhd.)
#3.01, Level 3, Wisma Academy
Lot 4A, Jalan 19/1
46300 Petalig Jaya
Malaysia

Océ-Nederland B.V.
P.O.Box 800
5201 AV 's-Hertogenbosch
The Netherlands

Océ Norge A/S
Postboks 53, Grefsen
0409 Oslo 4
Norway

Océ-Poland Ltd.
ul. Łopuszańska 53
02-232 Warszawa
Poland

Océ-Lima Mayer S.A.
Av. José Gomes Ferreira, 11
Ed. Atlas II Miraflores
1495 Algés
Portugal

Océ (Far East) Pte. Ltd./
Océ (Singapore) Pte. Ltd.,
#03-00 Wisma Gulab
190 MacPherson Road
Singapore 348548

Océ España SA
Business Park MAS BLAU
C/Osona 2, 2-3a Planta
08820 El Prat del Llobregat (Barcelona)
Spain

Océ-Svenska AB
P.O.box 1231
S-164 28 Kista
Sweden

Océ-Schweiz AG
Sägereistrasse 29
CH8152 Glattbrugg
Switzerland

Océ (Taiwan) Ltd.
No. 99-24 Nan Kang Road Sec.2
Taipeh, Taiwan
Taiwan, RO

Océ (Thailand) Ltd.
16th Floor, B.B. Building
54 Asoke Road, Sukhumvit 21
Bangkok 10110
Thailand

Océ-U.K.Ltd.
Langston Road
Loughton, Essex IG10 3SL
United Kingdom

Océ-USA Inc.
5450 North Cumberland Av.
Chicago, Ill. 60656
U.S.A.

Index

A

auto roll selection 34, 36
Automatic language sensing 48
automatic roll switch 36
autoposition 76

B

baud rate 17
bitmap buffer 23
bits combination 18

C

CalComp 61
centronics port 15
centronics protocol 99
Checksum 62
connector
 centronics 101
 serial 102
cut method
 programming 42
cutting paper 30

D

demo print 44
Designjet
 Compatibility 58
double synchronization 65

E

end of message 63
end of print 73

end-of-plot time-out 73

F

flush media saver 77
framing 18
full menus 87

H

handshake protocol 16
high-capacity delivery tray 8

I

input buffer 22
inter-character delay 21
interfaces 99

L

Language recognition 49
leading edge 43
 programming 43
line attributes 59
Load
 print media 26
locked menu 87

M

media saver 74
media saver plot size 78
media saver time-out 77
menu levels 87
Merge mode
 HP-GL 55
 HP-GL/2 58
merge mode
 CalComp 63

N

nesting 74

O

optional features 8

Origin 61

P

Page advance

HP-GL 55

HP-GL/2 57

paper formats 103

paper jam 94

parity 18

Pen priority

CalComp 62

HP-GL/2 57

Océ 53

pen settings 47

plot center 42

port configuration

centronics 101

serial 102

port type 19

Poster mode 80

PostScript

data format selection 68

manual data format selection 68

page layout 69

page size 69

PostScript level 2 8

PostScript option 68

print material 103

print media 26

Print origin

CalComp 61

HP-GL 54

HP-GL/2 56

Océ 51

print settings 46

printer operating panel 9

problems 92

product specifications 98

program

auto switch 36

automatic roll selection 36

default paper feed 35

media type 35

media width 35

R

refill toner 37

replot 79

rotation 83

S

safety data sheets 111

safety information 110

scaling 83

serial connector 102

serial port 16

serial protocols 99

short menus 87

standard cut 42

Step size

Océ 52

step size 66

CalComp 66

stop bits 18

synchro cut 42

synchronization code 64

T

trailing edge 43

programming 43

transmission speed 15

turnaround delay 20

Turning off

printer 12

turning the copier on

printer 12

W

waste toner bag 38